

MASTERVOLT

USERS MANUAL / GEBRUIKERSHANDLEIDING / BETRIEBSANLEITUNG
MANUEL UTILISATEUR / MANUAL DE UTILIZACION / INSTRUZIONI PER L'USO

MASS COMBI

12/2000-100, 12/4000-200, 24/2000-60 & 24/4000-120

SINE WAVE INVERTER/CHARGER COMBINATION
WITH GENERATOR / MAINS SUPPORT



MASTERVOLT
Snijdersbergweg 93,
1105 AN Amsterdam
The Netherlands
Tel.: +31-20-3422100
Fax.: +31-20-6971006
www.mastervolt.com

ENGLISH:	PAGE 1
NEDERLANDS:	PAGINA 45
DEUTSCH:	SEITE 89
FRANÇAIS:	PAGINA 133
CASTÉLLANO:	PÁGINA 177
ITALIANO:	PÁGINA 221

CONTENTS:

v 3.1. April 2006

1	GENERAL INFORMATION.....	4
1.1	Use of this manual.....	4
1.2	Guarantee specifications.....	4
1.3	Validity of this manual.....	4
1.4	Quality.....	4
1.5	Liability.....	4
1.6	Identification label.....	4
1.7	Changes to the MASS COMBI.....	4
2	SAFETY GUIDELINES AND MEASURES.....	5
2.1	Warnings and symbols.....	5
2.2	Use for intended purpose.....	5
2.3	Organizational measures.....	5
2.4	Maintenance & repair.....	5
2.5	General safety and installation precautions.....	5
2.6	Warning regarding life support applications.....	6
2.7	Warning regarding the use of batteries.....	6
3	HOW IT WORKS.....	7
3.1	The battery charger.....	7
3.1.1	Three step Plus charge system.....	7
3.1.2	Temperature compensated charging.....	8
3.1.3	Connection of a second battery.....	8
3.2	The inverter.....	8
3.2.1	General.....	8
3.2.2	Energy saving mode.....	8
3.3	Operation modes.....	9
3.3.1	Basic operation.....	9
3.3.2	The transfer switch.....	9
3.3.3	Power sharing function.....	9
3.3.4	Generator / mains support function.....	11
3.3.5	Power support function.....	11
3.3.6	Summary of the AC operation modes.....	12
3.4	Parallel operation.....	12
3.5	Remote control panels.....	13
3.5.1	Remote panel ICC.....	13
3.5.2	Remote panel APC.....	13
3.5.3	Masterlink MICC panel.....	13
3.6	Alarm contacts.....	14
3.7	MasterAdjust software.....	14
3.8	Batteries.....	14
4	OPERATION.....	15
4.1	Indicators.....	15
4.2	Switching On and Off.....	15
4.2.1	Switching on.....	15
4.2.2	Switching Off.....	16
4.2.3	Switching Ch. (Charger only).....	16
4.3	Protections.....	16
4.3.1	Transfer switch overload protection.....	16
4.3.2	Output overload or short circuit.....	16
4.3.3	Overheating.....	17

4.3.4	Under and over voltage	17
4.4	Inverter Charger Control panel	17
4.5	AC Power Control panel (optional)	18
4.6	Maintenance	18
4.7	Problem solving	18
5	INSTALLATION	19
5.1	Unpacking	19
5.2	Environment	19
5.3	Wiring	19
5.3.1	AC-wiring	19
5.3.2	DC wiring	20
5.3.3	AC safety grounding	20
5.4	Things you need	21
5.5	Removal of the front panel	22
5.6	Overview connection compartment	23
5.7	Mounting of the cabinet	25
5.8	Wiring instructions	25
5.8.1	Wiring instructions for one Mass Combi (stand alone operation)	27
5.8.2	Wiring instructions for two Mass Combi's (parallel operation)	29
5.8.3	Alarm contacts	30
5.9	Settings	30
6	SETTINGS	31
6.1	DIP Switch A	31
6.1.1	Parallel mode	31
6.1.2	Output frequency inverter	31
6.1.3	Energy saving mode	32
6.1.4	Battery type	32
6.1.5	Ground relay	32
6.2	DIP Switch B	33
6.2.1	Power sharing function	33
6.2.2	Power Support Function	33
6.2.3	Generator / mains support function	33
6.2.4	Setting for Power Quality at incoming AC	33
6.2.5	Combi/inverter control	34
6.2.6	Equalize mode	34
7	START-UP AFTER INSTALLATION	35
7.1	Commissioning	35
7.2	Decommissioning	35
8	TROUBLE SHOOTING	36
8.1	Fault indicators	36
8.2	Software version	37
9	TECHNICAL DATA	38
9.1	Specifications inverter	38
9.2	Specifications charger	39
9.3	Miscellaneous	40
9.4	Characteristics	41
10	ORDERING INFORMATION	43
11	EC DECLARATION OF CONFIRMITY	44

1 GENERAL INFORMATION

1.1 USE OF THIS MANUAL

This manual serves as a guideline for the safe and effective operation, maintenance and possible correction of minor malfunctions of the Mass Combi.

It is therefore obligatory that every person who works on or with the Mass Combi must be completely familiar with the contents of this manual, and that he/she carefully follows the instructions contained herein.

Installation of, and work on the Mass Combi, may be carried out only by qualified, authorised and trained personnel, consistent with the locally applicable standards and taking into consideration the safety guidelines and measures (chapter 2 of this manual).

Keep this manual at a secure place!

The English version has 44 pages.

1.2 GUARANTEE SPECIFICATIONS

Mastervolt guarantees that this unit has been built according to the legally applicable standards and specifications. Should work take place, which is not in accordance with the guidelines, instructions and specifications contained in this users manual, then damage may occur and/or the unit may not fulfil its specifications. All of these matters may mean that the guarantee becomes invalid.

The guarantee is limited to the costs of repair and/or replacement of the product. Costs for installation labor or shipping of the defective parts are not covered by this guarantee.

1.3 VALIDITY OF THIS MANUAL

All of the specifications, provisions and instructions contained in this manual apply solely to standard versions of the Mass Combi delivered by Mastervolt.

This manual is valid for the following models:

Description	Part number
Mass Combi 12/2000-100 / 230V	36012005
Mass Combi 12/4000-200 / 230V	36014005
Mass Combi 24/2000-60 / 230V	36022005
Mass Combi 24/4000-120 / 230V	36024005
Mass Combi 12/2000-100 / 120V	37012005
Mass Combi 12/4000-200 / 120V	37014005
Mass Combi 24/2000-60 / 120V	37022005
Mass Combi 24/4000-100 / 120V	37024005

For other models see other manuals available on our website: www.mastervolt.com

1.4 QUALITY

During their production and prior to their delivery, all of our units are exhaustively tested and inspected. The standard guarantee period is two years after date of purchase.

1.5 LIABILITY

Mastervolt can accept no liability for:

- consequential damage due to use of the Mass Combi;
- possible errors in the manuals and the results thereof.

1.6 IDENTIFICATION LABEL

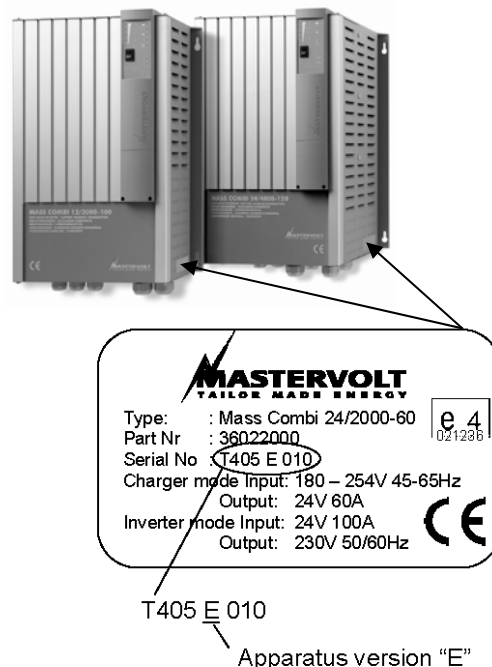

Figure 1: Identification label

The identification label is located at the right-hand side of the Mass Combi. (see figure 1) Important technical information required for service, maintenance & secondary delivery of parts can be derived from the identification label.



CAUTION!

Never remove the identification label.

1.7 CHANGES TO THE MASS COMBI

Changes to the Mass Combi may be carried out only after obtaining the written permission of Mastervolt. This is not applicable for DIP-switches (see chapter 6) which are used for making user settings.

2 SAFETY GUIDELINES AND MEASURES

2.1 WARNINGS AND SYMBOLS

Safety instructions and warnings are marked in this manual by the following pictograms:



A procedure, circumstance, etc which deserves extra attention.



CAUTION!

Special data, restrictions and rules with regard to preventing damage.



WARNING

A WARNING refers to possible injury to the user or significant material damage to the charger if the user does not (carefully) follow the procedures.

2.2 USE FOR INTENDED PURPOSE

- 1 The Mass Combi is constructed as per the applicable safety-technical guidelines.
- 2 Use the Mass Combi only:
 - for the charging of lead acid batteries and the supply of users attached to these batteries, in permanent systems;
 - for the conversion of a DC voltage from a battery to an AC voltage.
 - connected to a dedicated double pole circuit breaker and earth leakage switch.
 - with a fuse, protecting the wiring between Mass Combi output and battery;
 - in a technical correct condition;
 - in a closed, well-ventilated room, protected against rain, moist, dust and condensation;
 - observing the instructions in the users manual.



WARNING

Never use the Mass Combi in situations where there is danger of gas or dust explosion or potentially flammable products!

- 3 Use of the Mass Combi other than mentioned in point 2 is not considered to be consistent with the intended purpose. Mastervolt is not liable for any damage resulting from the above.

2.3 ORGANIZATIONAL MEASURES

The user must always:

- have access to the user's manual;
- be familiar with the contents of this manual. This applies in particular to chapter 2, Safety Guidelines and Measures.

2.4 MAINTENANCE & REPAIR

- 1 If the Mass Combi is switched off during maintenance and/or repair activities, it should be secured against unexpected and unintentional switching on:
 - remove the fuse(s) from the AC supply or switch off the AC circuit breaker;
 - switch off the connection with the batteries or remove the DC fuse(s);
 - be sure that third parties cannot reverse the measures taken.
- 2 If maintenance and repairs are required, use only original spare parts.

2.5 GENERAL SAFETY AND INSTALLATION PRECAUTIONS

- Do not expose the Mass Combi to rain, snow, spray, moisture, excessive pollution and condensing circumstances. To reduce risk of fire hazard, do not cover or obstruct the ventilation openings. Do not install the Mass Combi in a non-ventilated room, overheating may result.
- The Mass Combi must be provided with an equipment-grounding conductor to the AC-input ground terminal. Grounding and all other wiring must comply with local codes and ordinances.
- In case of fire, you must use the fire extinguisher which is appropriate for electrical equipment.
- Short circuiting or reversing polarity will lead to serious damage to batteries, Mass Combi and the cabling. Fuses between the batteries and the Mass Combi can not prevent damage caused by reversed polarity and the warranty will be void.
- Secure the DC wiring with a fuse, according to the guidelines in this manual.
- Connection and protection must be done in accordance with local standards.
- Do not work on the Mass Combi or system if it is still connected to a power source. Only allow changes in your electrical system to be carried out by qualified electricians.

- Check the wiring at least once a year. Defects such as loose connections, burned cables etc. must be corrected immediately.
- Do not touch the equipment when wet or if your hands are clammy.
- Not only the batteries, but the Mass Combi as well can become a projectile if your transport is involved in an accident! Ensure adequate and secure mounting and always use suitable handling equipment for transportation.
- Except for the connection compartment, see section 5.5, the cabinet of the Mass Combi must not be opened. There are no serviceable parts inside the cabinet. Only qualified, authorized and trained electrician installers are authorized to open the connection compartment.

2.6 WARNING REGARDING LIFE SUPPORT APPLICATIONS

The Mass Combi products are not sold for applications in any medical equipment intended for use as a component

of any life support system unless a specific written agreement pertaining to such intended use is executed between the manufacturer and Mastervolt. Such agreement will require the equipment manufacturer either to contract additional reliability testing of the Mass Combi parts and/or to commit to undertake such testing as a part of the manufacturing process. In addition the manufacturer must agree to indemnify and not hold Mastervolt responsible for any claims arising from the use of the Mass Combi parts in the life support equipment.

2.7 WARNING REGARDING THE USE OF BATTERIES.

Excessive battery discharge and/or high charging voltages can cause serious damage to batteries. Do not exceed the recommended limits of discharge level of your batteries. Avoid short circuiting batteries, as this may result in explosion and fire hazard. Installation of the batteries and adjustments of the Mass Combi should only be undertaken by authorised personnel!

3 HOW IT WORKS

This chapter describes the various applications of the Mass Combi series from Mastervolt.

The Mastervolt Mass Combi is a battery charger, a powerful sine wave inverter and an AC transfer system in one compact enclosure. The three-step Plus charging method guarantees that the batteries are always charged to 100%. The pure sine wave inverter assures that the AC output voltage is perfectly reliable even when limited external AC power is available. External AC power can be supplied by a public grid or a generator. DC power can be delivered by charged batteries.

3.1 THE BATTERY CHARGER

The built-in battery charger is electronically controlled. It is designed for optimal recharging of both wet cell, gel cell and AGM deep cycle batteries. Battery charging is accomplished in three automatic stages: BULK, ABSORPTION and FLOAT. With an external AC source connected, the Mass Combi charger also serves the functions of an AC to DC converter to supply DC loads which are connected to the battery. Simple, automatic operation is made possible by the microprocessor that is the brain of the inverter/charger combination. In most cases, the unit is left on and no attention or maintenance is required.

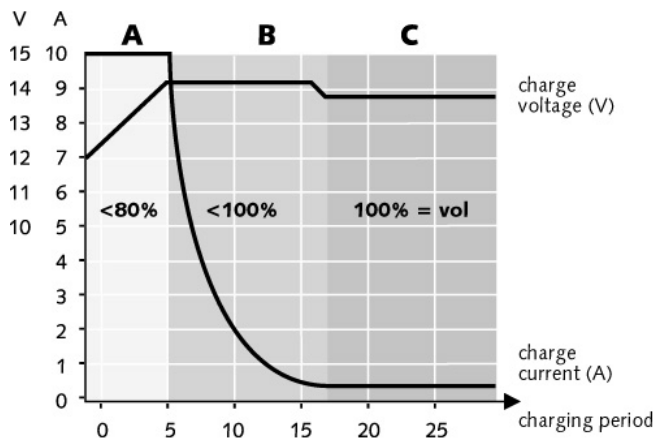

Figure 2:
Three step Plus charge system

3.1.1 Three step Plus charge system

See figure 2. The first step of the three step Plus charge system is the BULK phase (A), in which the output current of the charger is 100%, and the greater part of the capacity of the battery is rapidly charged. The current charges the batteries and gradually the voltage rises to the absorption voltage of 14.25V (12V models) or 28.5V (24V models) @ 20°C / 68°F.

The duration of this phase depends on the ration of battery to charger capacity, and naturally also on the degree to which the batteries were discharged to begin with.

The bulk phase is followed by the absorption phase. (B) Absorption charging starts when the voltage on the batteries has reached 14.25V (12V models) / 28.5V (24V models) @ 20°C / 68°F, and ends when the battery is completely full. Battery voltage remains constant throughout this stage, and the charge current depends on the degree to which the battery was initially discharged, the battery type, the ambient temperature, and so on. With a wet cell battery this stage lasts some four hours, with gel and AGM around three. Once the battery is 100% full, the Mastervolt charger automatically switches over to the float phase.

During the float phase (C) the Mass Combi switches to 13.25V (12V models) or 26.5V (24V models) @ 20°C / 68°F and stabilises this voltage to maintain the batteries in an optimum condition. Connected consumers are powered directly by the charger. If the load is higher than charger capacity, the required additional power comes from the battery, which will be progressively discharged until the charger automatically switches back to the bulk phase. Once consumption decreases, the charger goes back to normal operation of the three-step charge system.

As the Mass Combi is equipped with a three-step Plus charge system, the batteries can also remain connected to the Mass Combi in winter. One hour every 12 days the charger automatically switches to absorption to keep the battery running properly and prolong its life span. The three-step Plus charge system is also safe for all the connected equipment.

See also section 9.4 for detailed characteristics of the three step Plus charge system.

3.1.2 Temperature compensated charging

The Mass Combi is delivered with a battery temperature sensor. By installing this battery temperature sensor the charge voltages are automatically adapted for deviating temperatures.

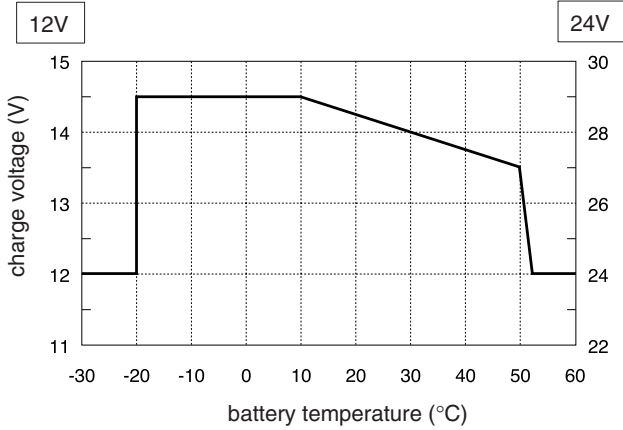

Figure 3:
Temperature compensated charging

See figure 3 When the battery temperature is low, the charge voltage increases. On the other hand, when the battery temperature is high, the charge voltage is decreased. Over charge and gassing are prevented this way. This will extend the life of your batteries.

See section 5.8 to connect the battery temperature sensor.

3.1.3 Connection of a second battery

The Mass Combi is equipped with second charge output which can be used to give a maintenance charge to a small battery set like a starter battery Maximum output current: 5 Amps.

Output voltage: same as the main charger.

See section 5.8 for connection.

3.2 THE INVERTER

3.2.1 General

The inverter provides voltage and frequency regulated AC power from a battery bank. Fast acting electronic circuits protect the inverter against extreme overloads, low and high battery voltage and overheating of the inverter.

Considerable momentary surge power is available for starting-up electric motors. High efficiency insures long battery usage between recharges. A built in energy saving feature can reduce battery power consumption when the inverter is unloaded.

3.2.2 Energy saving mode

In the inverter mode the Mass Combi has a built-in automatic energy saving feature that reduces battery power consumption when no load is present on the "SHORT BREAK" output. Response from idle is instant. In most cases the operation is not noticeable. Four modes can be set by means of DIP-switches, see chapter 6.

The inverter of the Mass Combi can operate in one of the following modes (table 1):

Mode	Explanation
High power	The energy saving mode is switched off. The inverter is fully operating and the output voltage is 230V (120V) AC. This is the default setting.
Idle 40VA	The inverter reduces, below the 40VA or 150VA connected load, the output voltage almost to zero. The Mass Combi scans the "SHORT BREAK" outlet with pulses of 230V (120V) every 2½ seconds. When it detects a load that is larger than 40VA or 150VA, it switches on the inverter automatically. Small loads such as clocks in VCR's or micro waves are most likely not to work on this mode.
Idle 150VA	
Economy mode	The inverter reduces the output voltage to 208V (104V) AC if the connected load drops below 250VA. The output voltage will return to 230V (120V) AC if the connected load rises above 250 VA. Small loads as clocks in VCR's and micro waves will perform equal whether the inverter is running in the economy state or is on. The saving is approximately 10%.

For detailed specifications see section 9.1 "DC no load power consumption"

Table 1 : Mass Combi energy saving modes

3.3 OPERATION MODES

The Mass Combi is not just a combination of an inverter and a battery charger. It has many additional features which can be used to increase the total available AC power, even when external AC power is limited.

3.3.1 Basic operation

When there is no external AC power available, the inverter of the Mass Combi provides AC power on the "SHORT BREAK" output from the batteries. There is no AC power available on the "POWER" output. Now the Mass Combi is in "Inverter mode". See figure 4.

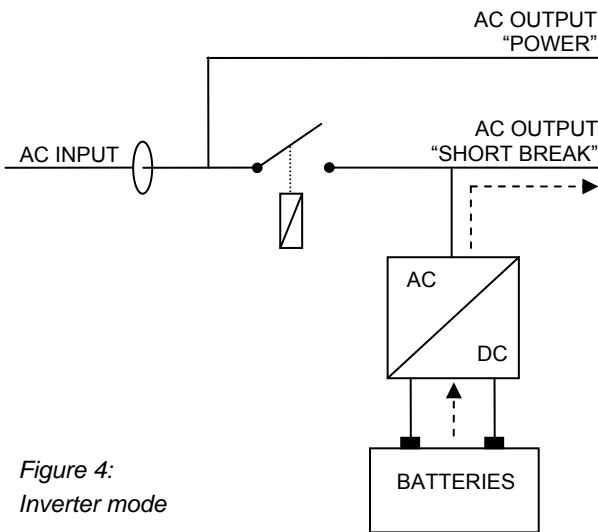

Figure 4:
Inverter mode

When external AC power comes available, the transfer relay switches on. See figure 5. Both outputs as well as the battery charger are supplied by the external AC power. The batteries are recharged now. Now the Mass Combi is in "Charger mode"

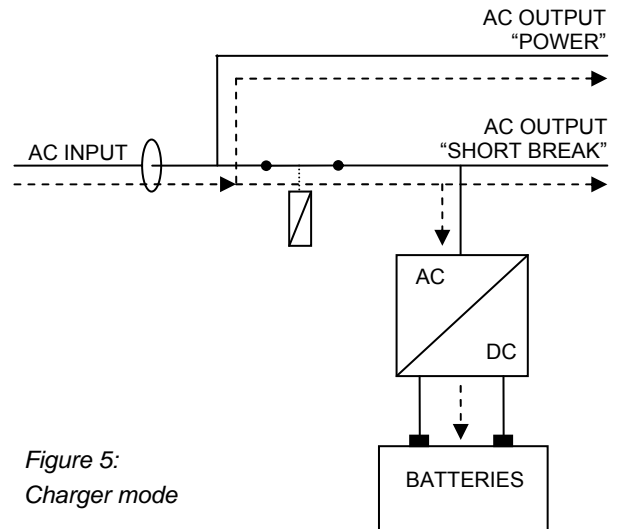

Figure 5:
Charger mode

3.3.2 The transfer switch

The Mass Combi has two AC-outputs available;

- SHORT BREAK output. The "SHORT BREAK" output switch is between the AC-input and the output of the inverter. The AC input has the highest priority. In principle, AC-power is always available on this output. However during a switchover the loads connected to this output are not supplied with AC-power for a very short period of time (short break). It is the ideal output for loads that AC-power continuously like personal computers, interior lightning and the refrigerator.
- POWER output. This output is always internally connected to the AC-input. It is therefore only available when an external AC-source like shore power, a generator or an outlet is present. Larger loads like a hot water boiler, electric cooking appliance or washing machine should be connected to this output

3.3.3 Power sharing function

If the available power at the AC-input is limited, and the load connected to the AC output increases, the external AC circuit breaker may trip if nothing is done. To avoid this, the Mass Combi can automatically reduce the battery charger output, and thus the AC power consumption. This *Power sharing* feature constantly senses the incoming AC current which is used to supply both the battery charger and the appliances connected to the AC outputs.

The *Power Sharing level* should be set to match the value of the external circuit breaker, which protects the incoming AC power. For instance, when the external AC power is limited by a 6A fuse, the *Power Sharing level* must be set to 6A.

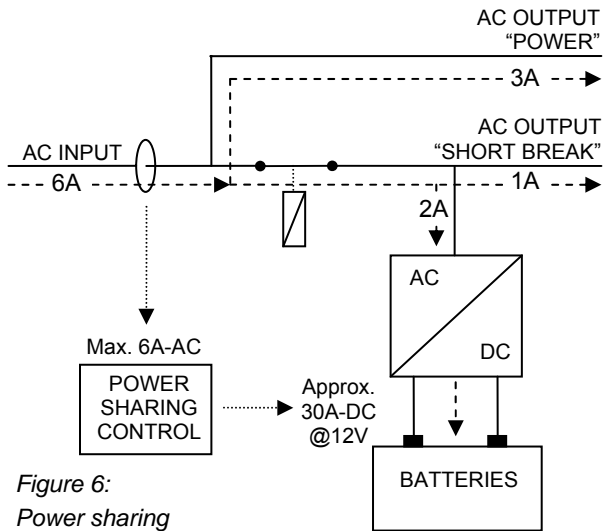

Figure 6:
Power sharing

See figure 6.

Here the *Power Sharing level* is set to a 6 Amps while the AC outputs consume a total of $1 + 3 = 4$ Amps. This means that only $6 - 4 = 2$ Amps is left over for charging. With 12V batteries this will result in a maximum charge current of approx. 30A DC

Although the *Power Sharing level* can be set by means of the DIP-switches locally on the Mass Combi (see section 6.2.1), we recommend the use of the optional APC or MICC remote control panel. With this remote panel you can select the available shore current (fuse) of each marina or camping site in a very easy way.

When the total connected AC load reaches the level of the Power Sharing setting (6A), there will be no power left over to charge the battery. This means that the charge current of the will be reduced to 0A. See figure 7.

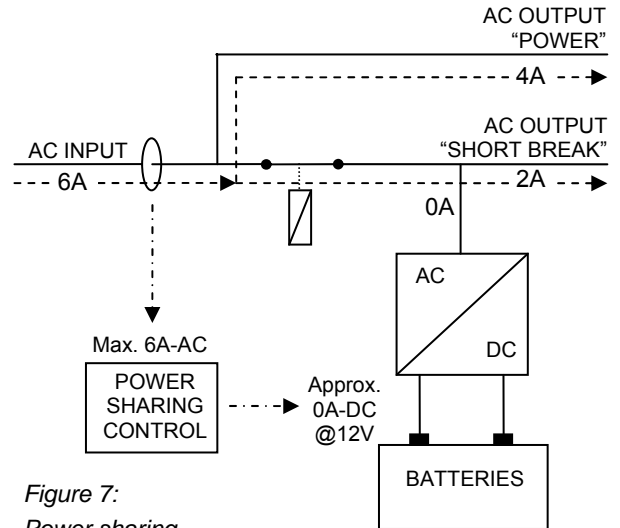

Figure 7:
Power sharing

3.3.4 Generator / mains support function

If the demand for AC power still increases, the external AC circuit breaker may still trip if nothing is done. This problem will be solved by the *Generator / mains support function*. If the total demand for energy is more than the external power supply can deliver, even more energy can be added to the AC outputs “POWER” and “SHORT BREAK” by means of the inverter, which can be automatically connected in parallel with the external power supply.

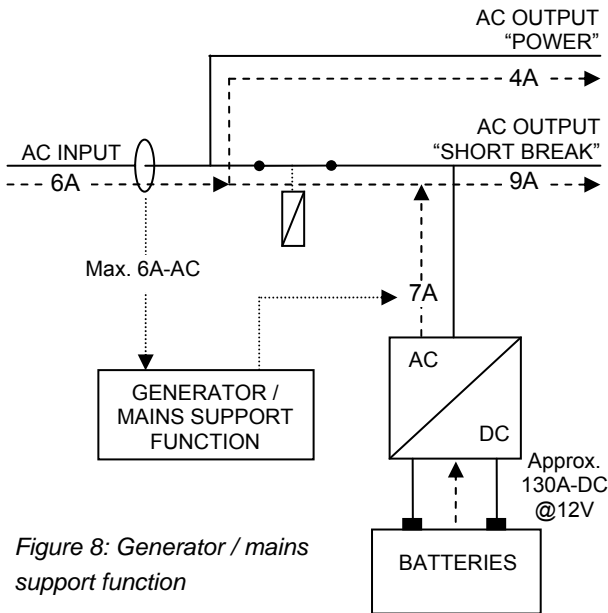

Figure 8: Generator / mains support function

See figure 8

Here the AC-input is still limited to 6 Amps. This is not enough to supply the total load (4 + 9A = 13A) connected to the AC outputs.

When the *Generator / mains support function* is enabled, the inverter will supply the remaining 13 – 6 = 7A. This means that the restricted amount of external AC power will be compensated by energy which is stored in the batteries.

Later, when the AC load has dropped below the setting of the Power sharing function again, the battery charger of the Mass Combi will commence to recharge the batteries. For safety reasons the transfer relay is immediately switched off when incoming AC power fails in operation so that there will never be a high voltage on the shore cable inlet when it is not connected.

3.3.5 Power support function

As explained above, when the *Generator / mains support function* is enabled, the inverter will operate in parallel with the external AC power source. This means that energy from the batteries can also be added to the public grid. In fact, your Mass Combi will turn into a small power station. Please mind that several countries maintain different regulations with regard to the feedback of energy to the public grid. This may mean that in some situations the use of the *Generator / mains support function* is not allowed. Please acquaint yourself with local regulations on this issue. Never use the *Generator / mains support function* if this is not allowed!

Even if the use of the *Generator / mains support function* is not allowed, it is still possible to supply more energy than the external power supply can deliver. This can be achieved by using the *Power support function*.

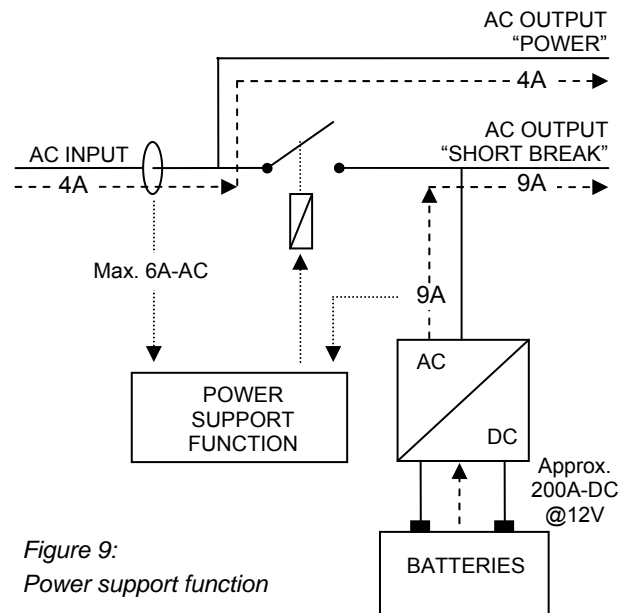

Figure 9: Power support function

See figure 9

The AC-input is still limited to 6 Amps. This is not enough to supply the total load (4 + 9A = 13A) connected to the AC outputs.

Now when the *Power support function* is enabled, the transfer relay will open. When opened, the external power source will deliver 4A to supply the load connected to the “POWER” output only, while the inverter will deliver 9 Amps for the load connected to the “SHORT BREAK” output.

Please note that if the power consumption of the “POWER” output exceeds the setting of the power support function, external AC fuse is still threatened to trip

If the total current from the “POWER”-output and “SHORT BREAK”-output is less than the *Power support* setting during approx. 10 minutes, the Mass Combi connects the “SHORT BREAK” output back to the AC-input again. The charger commences charging again when the load reduces further and the total current drops below the *Power sharing* setting.

3.3.6 Summary of the AC operation modes

Function	DIP-switch*	What is it used for?	How is this achieved?
Power Sharing	B-SW3	To protect the incoming AC from overload	By reducing the charge current and thus the AC input current.
Generator / Mains support	B-SW5	To deliver more AC power than available from the incoming AC.	The AC output of the inverter is connected in parallel with the incoming AC. This means that energy from the batteries is added to the incoming AC.
Power support	B-SW4	To deliver more AC power than available from the incoming AC.	The load which is connected to the “POWER”-output is supplied by the incoming AC, while the SHORT BREAK output is connected to the output of the inverter.

Table 2: Overview of the AC operation modes

* see chapter 6 for adjustment of the DIP-switches

3.4 PARALLEL OPERATION

If 2 kW of inverter power is not sufficient, yet another identical Mass Combi can be connected in parallel to double both the inverter power and the charge power. With two units in parallel the total inverter power conversion will be equally divided between the two units. To achieve this, one of the units must be configured by means of a DIP-switch setting as ‘master’ and the other as ‘slave’. See figure 10. Once the configuration is established the master tells the slave apparatus what to do. This communication is done by the use of a modular communication cable between the two units.

Note: Only two units of the Mass Combi 12/2000-100 or the Mass Combi 24/2000-60 can be connected in parallel. Parallel operation of two units of the Mass Combi 12/4000-200 or the Mass Combi 24/4000-120 is not possible.

See section 5.8.2 for connection and settings.

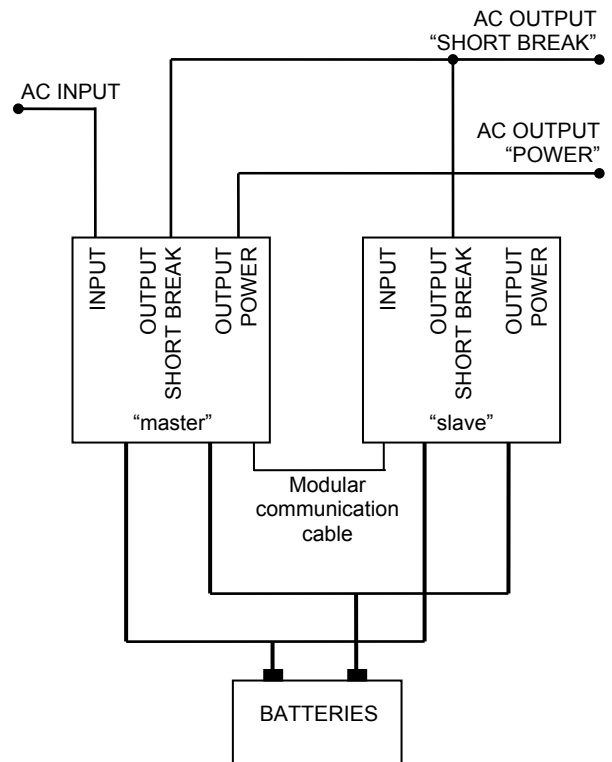

Figure 10: Parallel operation

3.5 REMOTE CONTROL PANELS

There are three remote panels available for the Mass Combi. The *Inverter Charger Control (ICC)* panel and the *AC Power Control (APC)* panel are specially designed for the Mass Combi. The *Mass Inverter Charger Control (MICC)* is a universal panel. However, it is not possible to connect all three panels at the same time. Mastervolt recommends to use the combination ICC and APC or to use the MICC panel only.

The remote panels are connected to the Mass Combi via a modular communication cable with two RJ 12 connectors. The maximum length of communication cable should not exceed 15m/49ft. The cables are available in the following length:

Art. Nr.	Description
6502001030	Modular communication cable, 6m/19ft
6502100100	Modular communication cable, 10m/33ft
6502100150	Modular communication cable, 15m/49ft

3.5.1 Remote panel ICC



The ICC panel provides the same functions as the user panel on the Mass Combi. However, with this remote panel you have the convenience to operate the Mass Combi remotely. This ICC remote panel and remote cable (6m) are included with the delivery of the Mass Combi.

3.5.2 Remote panel APC



The APC panel has extended functions such as setting remotely the Power sharing value and monitoring your "AC-load". This APC remote panel is optional (art. No 70405010).

3.5.3 Masterlink MICC panel



The Masterlink MICC panel (art. no 70403105) is a digital remote panel that has additional features compared to the ICC and APC panel. This sophisticated panel is not only a remote control panel to switch on and off your Mass Combi but also a battery consumption meter for read-out of the exact state-of-charge of your battery by means of a shunt. (included with the delivery of the Masterlink MICC) When the battery is reaching a low voltage set point or a low state-of-charge an alarm will be raised. This can be used to startup the generator.

The information provided includes reading voltage, current, Ah, time remaining and remaining capacity as a percentage of the maximum available battery capacity.. A well-lit LCD screen also displays direct online data or historical information. A protective back box, easy to install, is included as standard for protecting the electronic components against moisture and dust. This panel is suitable for MasterVision, Mastervolt's modular central switchboard with various monitoring functions.

3.6 ALARM CONTACTS

The Mass Combi is equipped with an integrated alarm function. External equipment can be controlled by the potential free contacts of this alarm (see 5.8.3). The maximum switch current of the relay is 1A. By default the relay will be activated when the DC-voltage is out of range, after a delay of 30 seconds. See table 3. Other functions can be programmed by means of MasterAdjust software (see section 3.7)

Nominal voltage:	12V	24V
Under voltage ON:	16.0V	32.0V
Under voltage OFF:	15.5V	31.0V
Over voltage ON:	10.0V	20.0V
Over voltage OFF:	11.0V	22.0V

Table 3

3.7 MASTERADJUST SOFTWARE

Mastervolt offers several free to download software, available from the website www.mastervolt.com.



The Mass Combi MasterAdjust software allows you to easily check the status of the charger, inverter and transfer system and to set the parameters of your Mass Combi so as to meet your personal requirements.

Use of a Mastervolt “PC link” for communication via the QRS232 communication port of the Mass Combi is required. See ordering information. See the user manual of the MasterAdjust software for detailed information. If your computer does not have a COM-port (RS232), use of a external USB-RS232 converter is necessarily.

3.8 BATTERIES

For use with the Mass Combi Mastervolt recommends at least semi traction batteries.

Battery type	Typical application	Number of cycles*
Starter battery	Very high current for a very short time.	40~60
Semi traction battery	High current for a long time.	200~400
Traction battery	High current for a very long time	1000~1500

*A cycle is one full discharge and one full charge.

Table 4: Typical applications of batteries

From the table it becomes clear that service life of starter batteries in cyclic applications can be less than two months. A semi traction battery can attain a service life of 5 years if the number of cycles is limited to 50 per year.

4 OPERATION

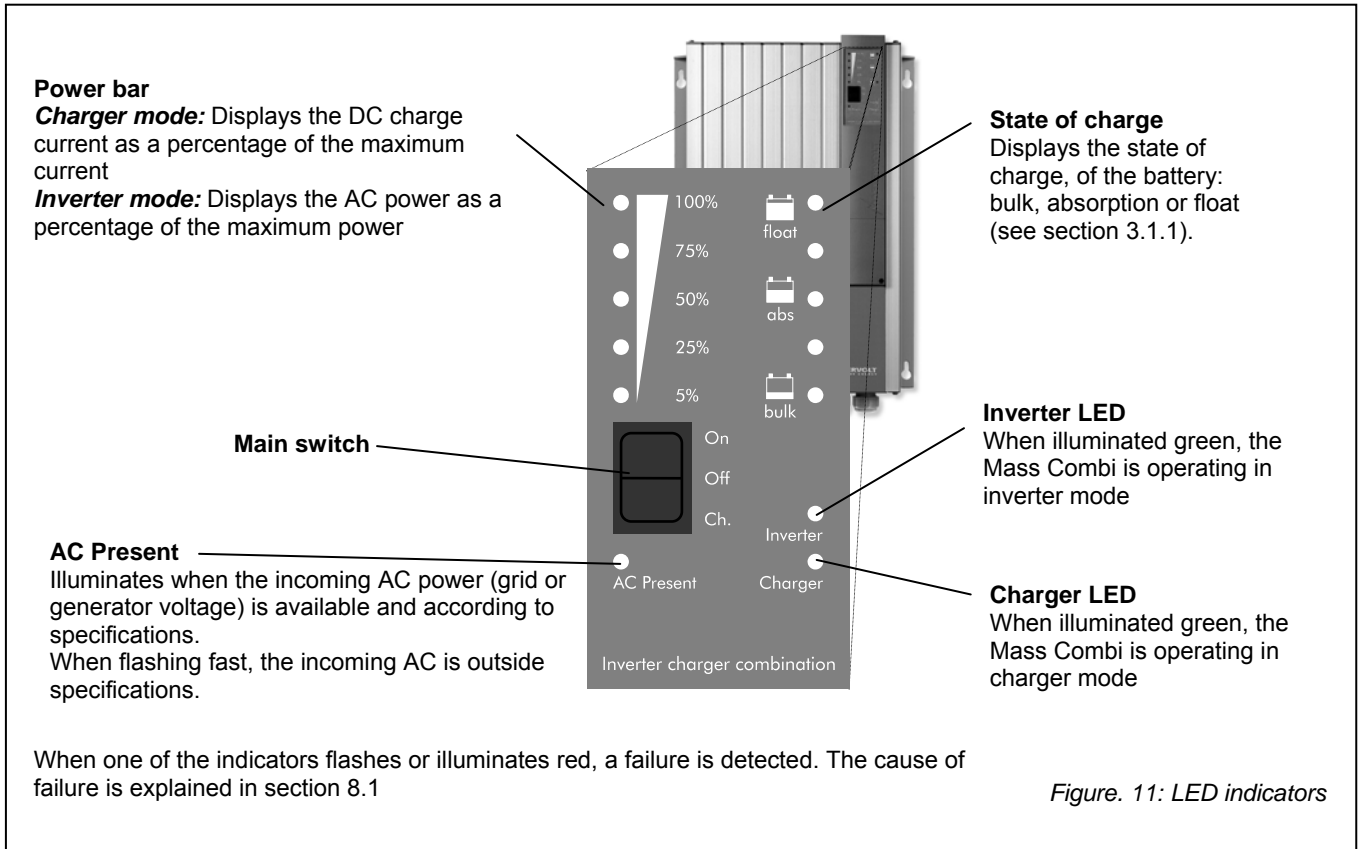

The Mass Combi is a fully automatic inverter / charger system. Under normal circumstances there is no need for adjustment or operation besides switching on and off.



If two Mass Combis are installed in parallel, the slave unit will only operate properly after the master unit was switched on first.



WARNING

Never disconnect any of the wiring during operation of the Mass Combi

4.1 INDICATORS

See figure 11. The operation of the Mass Combi is displayed by means of LED indicators at the front side of the housing. If the Mass Combi is activated and as long as none of the red indicators are illuminated, no failure is detected and the unit is operating normally.

4.2 SWITCHING ON AND OFF

The only control on the Mass Combi itself is the main switch (see figure 11) on the front of the unit. This switch controls On, Off and Ch. (Charger only)

4.2.1 Switching on

The Mass Combi can be activated by switching the main switch to the "ON" position.

If you use a remote control panel, press the on/off button on the remote control panel (See section 4.4).

After switching on expect a three till five second delay before the unit is activated. The LED-indicators will blink several times, indicating the installed software version (see section 8.2 for explanation).

If AC power is available on the AC input and within the specified limits, the Mass Combi will switch to Charger Mode and will commence to charge the batteries. At the same time the internal transfer relay will pass the AC power to the AC output "SHORT BREAK".

If the AC power from the external AC-source is unavailable or outside the specified limits, the unit will come on as an inverter. Inverter overload protection, built idle mode circuitry, transfer switching, power sharing and battery charger regulation will all function automatically.

4.2.2 Switching Off

Move the main switch to the “Off” position to switch off the Mass Combi. If you use a remote control panel, press the on/off button on the remote control panel (See section 4.4). The Mass Combi stops and all the indicators go off. The “Short” break output is disconnected and will become powerless.



WARNING

Switching off the Mass Combi with the main switch on the front of the cabinet does not cut off the connection to the batteries or the AC-source. Therefore the “POWER” output is still active



NOTE! When the main switch is in the “Off”-position, it overrides the remote control panel. In this off state it is not possible to start the Mass Combi remotely.

4.2.3 Switching Ch. (Charger only)

When the main switch is set to the “Ch.”-position, the Mass Combi is only able to work as a charger. This means that the inverter mode is disabled. This setting is useful if you want to keep your batteries charged and maintained in case you are away i.e. in the winter time. Now your batteries are spared when the incoming AC-source fails in operation.

If you use the remote panel ICC or MICC you can still switch-on/off the charger remotely, even if the incoming AC-source is not available. If the AC-source is available and the Mass Combi is operating in the charger mode, the user panel shows the actual status of the system.

See section 4.4 for detailed operation instructions of the remote panel ICC.

4.3 PROTECTIONS

The Mass Combi is protected against overload, short circuit, over heating and under and over voltage. The user can readout the detected failure from the local user panel or from one of the (optional) remote control panels by means of indicators

See section 8.1 for explanation of this readout.



CAUTION!

The Mass Combi is not protected against reversing polarity of the DC-input, AC voltage on the DC-input and serious over voltage (>265VAC) on the AC-input or AC-output.

4.3.1 Transfer switch overload protection

The transfer switch of the Mass Combi is protected against overload and short circuit. When the current through the transfer switch of the Mass Combi is too high (see figure 31) the thermal fuse (figure 18 or 19) will switch off and the Mass Combi shuts down.

To correct this situation, proceed as follows:

- 1 Move the main switch of the Mass Combi to the “OFF”-position.
- 2 Disconnect the Mass Combi from any power source. Disconnect all loads from the Mass Combi.
- 3 Investigate the cause of failure of the thermal fuse like overload or short-circuits.
- 4 Refer to section 5.5 to open the connection compartment
- 5 Wait for at least two minutes and then reset the thermal fuse by pushing the button inside the connection compartment (see figure 12).

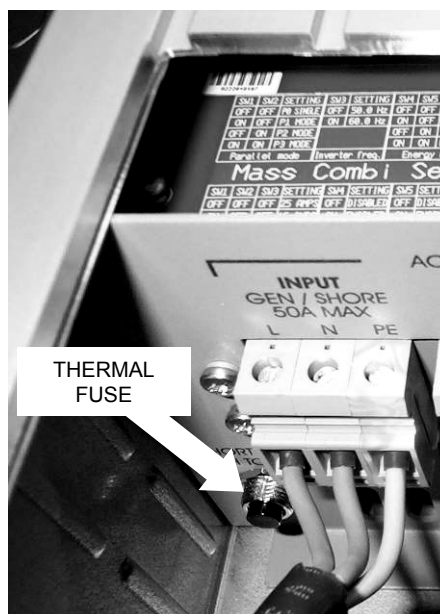

Figure 12: Reset of the thermal fuse

- 6 Close the connection compartment again.
- 7 Connect the Mass Combi to the power sources again.
- 8 Switch on the Mass Combi. (see section 4.2)

4.3.2 Output overload or short circuit

In case of overload or short circuit in the inverter mode, the 100% LED of the Power bar (see figure 11) is illuminated red and the output voltage of the Mass Combi is limited. The Mass Combi shuts down if this overload or failure lasts longer than 5 seconds.

The Mass Combi will automatically restart after shutdown. After 5 failed start attempts the Mass Combi shuts down permanently, the 100% LED is lit and the Inverter LED

(see figure 11) will flash. You can restart the Mass Combi only by switching the unit manually off and on with the main switch on the Mass Combi after the overload is removed or failure is solved.

4.3.3 Overheating

In the event of overheating the Mass Combi shuts down. The Mass Combi is automatically powered up again when the temperature drops below the factory default threshold.

Overheating is most likely caused by:

- heavy or non-resistive loads operating for a longer time
- high ambient temperature
- disrupted air flow (dust or too less space)

4.3.4 Under and over voltage

The AC-input of the Mass Combi is, within limits, protected against over and under voltage. See specifications in section 9.2. The Mass Combi will switch to inverter mode if the AC-input voltage is out of operating range and will switch back if the AC-input voltage is present again.

The DC-input of the Mass Combi is also, within limits, protected against over and under voltage. See specifications in section 9.1. The Mass Combi switches off if the DC-input voltage is out of range.

4.4 INVERTER CHARGER CONTROL PANEL

The Inverter Charger Control (ICC) remote control panel is standard included with the delivery of each Mass Combi. See figure 13. With this panel you can operate and check the actual status of the Mass Combi remotely.

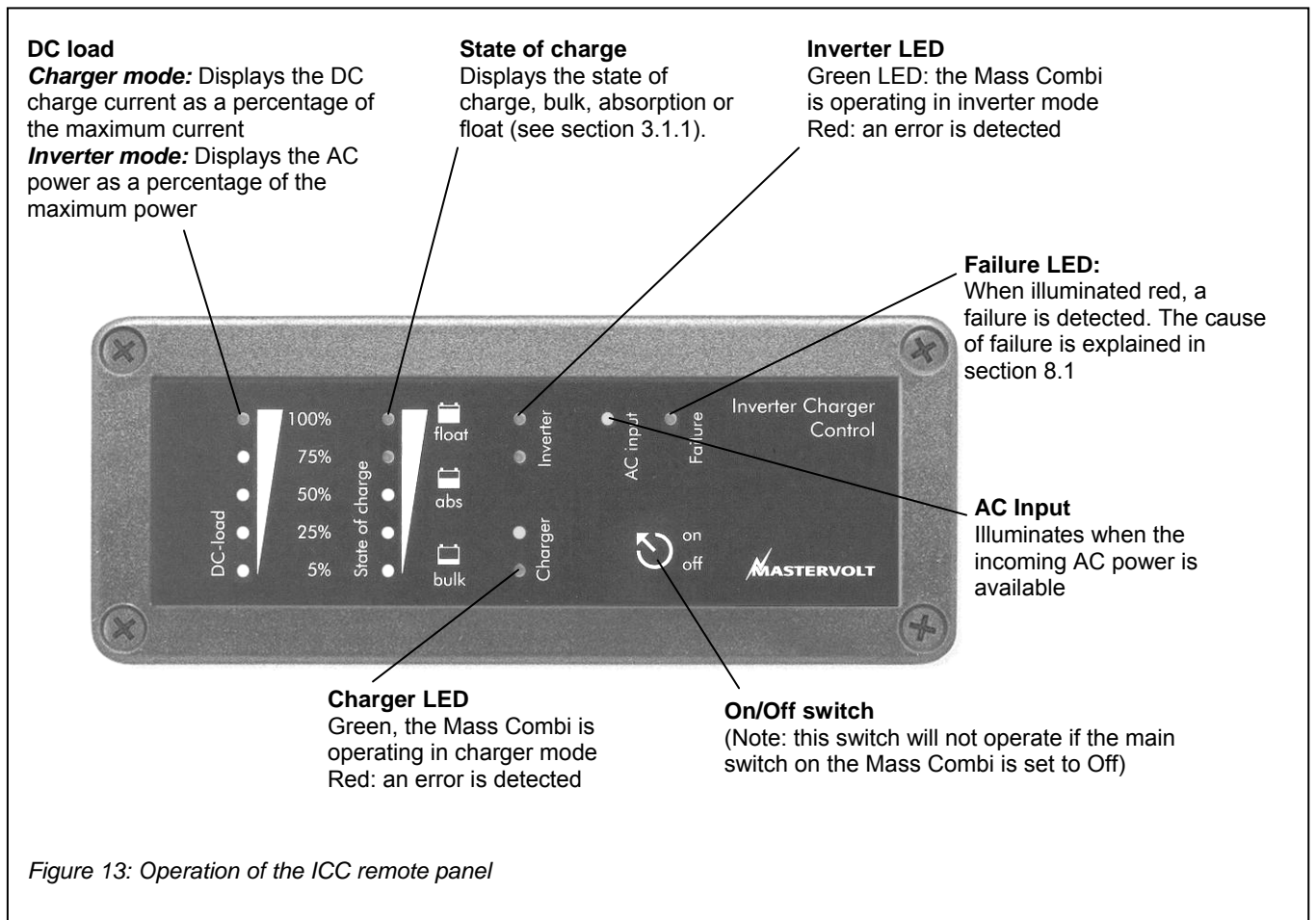

Figure 13: Operation of the ICC remote panel

4.5 AC POWER CONTROL PANEL (OPTIONAL)

The optional AC Power Control remote panel enables you to limit the incoming AC-input current. By adjusting this setting the AC-input source can be protected against an overload situation. This setting is used to control the power sharing function, the generator / mains support function and the power support function. See figure 14

This panel is orderable via article number 70405010



NOTE! The setting for maximum input current can never be adjusted to a level that is higher than set by DIP-switches B1 and B2 of the Mass Combi. Example: If the dipswitches of the Mass Combi are adjusted to 10 Amps, it is only possible to scroll between 4, 6 and 10 Amps.

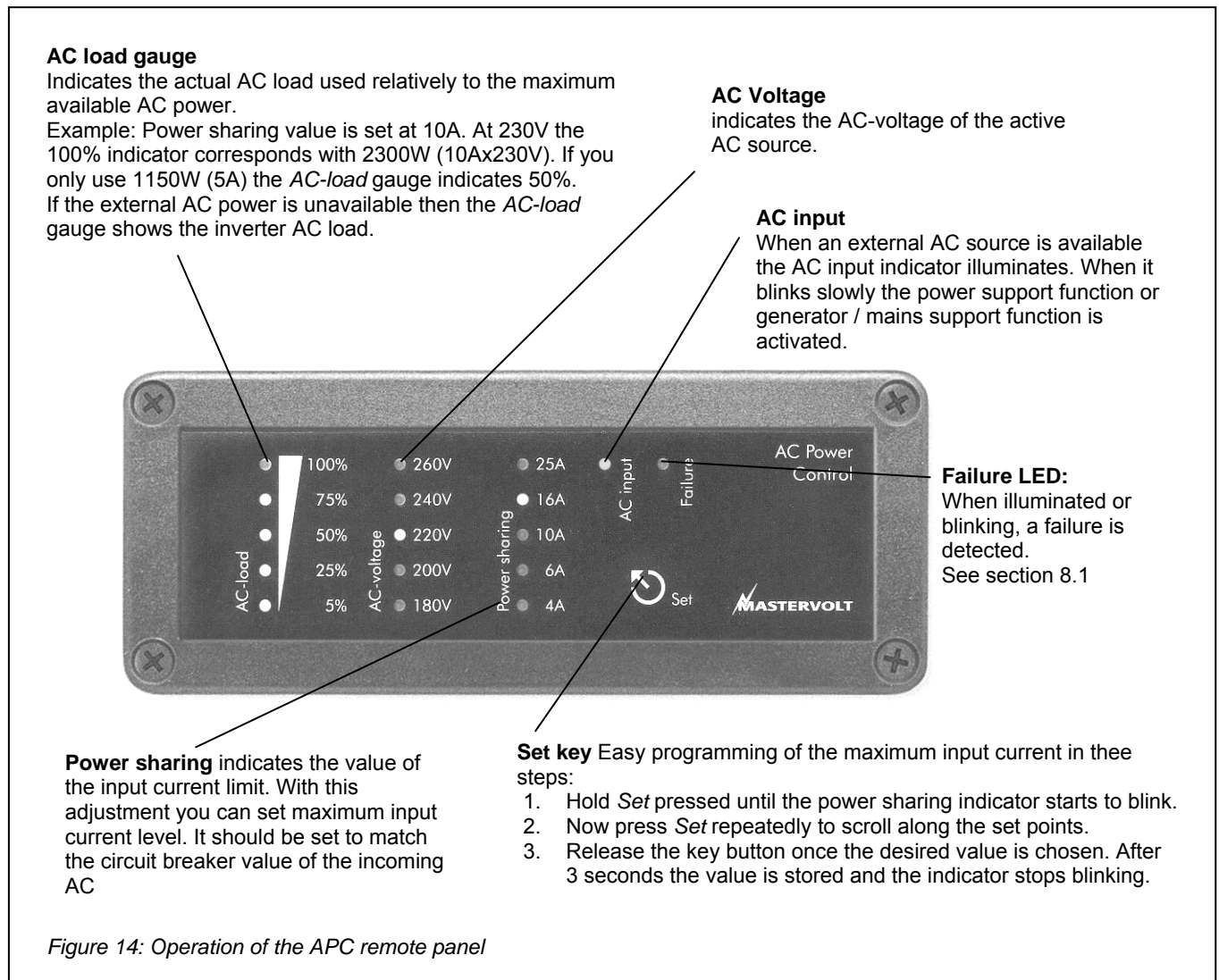

4.6 MAINTENANCE

No specific maintenance is required. If necessary, use a soft clean cloth to clean the Mass Combi. Never use any liquids, acids and/or scourers.

4.7 PROBLEM SOLVING

Refer to chapter 8 if a problem occurs.

5 INSTALLATION

During installation and commissioning of the Mass Combi, the Safety Guidelines & Measures are applicable at all times. See chapter 2 of this manual.

5.1 UNPACKING

In addition to the Mass Combi the delivery includes:

- a battery temperature sensor;
- a remote control panel: Inverter Charger Control (ICC) with grey mounting box and communication cable (6m)
- this user's manual.

After unpacking, check the contents for possible damage. Do not use the product if is damaged. If in doubt, contact your supplier.

Check from the identification label (see section 1.6) whether the battery voltage is the same as the DC-input voltage of the Mass Combi (e.g. 24V battery set for a 24V input voltage). Also check that the AC output voltage and output power of the Mass Combi satisfies loading requirements.

5.2 ENVIRONMENT

Obey the following stipulations during installation:

- The Mass Combi is designed for indoor use only.
- Ambient temperature: 0 ... 60°C / 32°F ... 140°F; (power derating above 25°C / 104°F to decrease the internal heat sink temperature)
- Humidity: 0-95% non condensing
- Mount the Mass Combi on a solid surface, with the connecting cables downwards.
- Make sure that the hot air that is developed during operation can be discharged. The Mass Combi must be mounted in such a way that obstruction of the airflow through the ventilation openings will be prevented.
- No objects must be located within a distance of 10 cm / 4 inch around the Mass Combi.
- Do not locate the Mass Combi in the same compartment as the batteries.
- Do not install the Mass Combi straight above the batteries because of possible corrosive sulphur fumes

5.3 WIRING

The wiring is connected inside the connection compartment. If necessary, the cabling can be fed from the top to the bottom side of the cabinet along the back of the cabinet.

Always feed the wiring through the cable glands of the cabinet, and then connect the wiring to the terminals. Fix the phase line wire to terminal L, the neutral wire to terminal N and the ground wire to terminal PE.

5.3.1 AC-wiring

For a safe installation the correct wire cross section must be applied. Don't use a cross section that is smaller than indicated. See table below to select the appropriate cross section for the AC wiring:

AC-Current	Minimum cross section:	
	in mm ²	AWG
15-20 Amp	2.5 mm ²	AWG 13
20-32 Amp	4 mm ²	AWG 11
32-48 Amp	6 mm ²	AWG 9
48-80 Amp	10 mm ²	AWG 7

Recommended wire colours:

- 117V AC installations:

Wire color	Meaning	Must be connected to:
Black	Hot or Line	L1
White	Neutral	N
Green	Ground	PE / GND

- 230V AC installations:

Wire color	Meaning	Must be connected to:
Brown or black	Phase	L1
Blue	Neutral	N
Green/Yellow	Earth	PE / GND

The maximum current passing the Mass Combi must be limited. Therefore the AC-input must be protected by a fuse, as specified below.

Model Mass Combi	Maximum rating of the AC input fuse
All models	50A

5.3.2 DC wiring

Keep in mind that high current will pass through the DC wiring. Keep the cable length as short as possible, this will keep the system efficiency as high as possible. The recommended minimum cross section of the battery cables is:

Model Mass Combi	DC Cable cross section:
12/2000-100	2x 70mm ² / AWG2/0
12/4000-200	4x 70mm ² / AWG2/0
24/2000-60	2x 50mm ² / AWG0
24/4000-120	2x 70mm ² / AWG2/0

Use ring terminals on the ends of the wires. The terminals should be crimped with a proper crimping tool. Use the following wire colours for DC wiring:

Wire color	Meaning	Must be connected to:
Red	Positive	+ (POS)
Black	Negative	- (NEG)

Lay the positive and negative cables next to each other to limit the electro magnetic field around the cables. The negative cable should be connected directly to the negative post of the battery bank or the ground side of a current shunt. Do not use the chassis frame as the negative conductor. Tighten securely. The positive battery cable must be fused and connected to the positive post of the battery bank, or through a selector switch to one or more battery banks.

Model Mass Combi	Recommended Combi fuse
12/2000-100	250A
12/4000-200	2 x 250A
24/2000-60	125A
24/4000-120	250A

The fuse with the fuse-holder is available from your local Mastervolt distributor or Customer Service Representative.

5.3.3 AC safety grounding



WARNING

The ground wire offers protection only if the cabinet of the Mass Combi is connected to the safety ground. Connect the earth terminal (PE / GND) to the hull or the chassis.



CAUTION!

For safe installation it is necessary to:

- connect the neutral conductor (N) of the AC output to the earth (PE / GND), only during inverter operation of the Mass Combi;
- insert a Residual Current Device (earth leakage switch) of 30mA in AC output "SHORT BREAK" of the Mass Combi.
- Insert a Residual Current Device (earth leakage switch) of 30mA in AC input of the Mass Combi.

Refer to local regulations on these issues!

For safety purposes the neutral conductor (N) of the AC output must be connected to the earth (PE / GND) when the Mass Combi is in inverter operation. When utility power is available on the AC input, and the Mass Combi is in charger mode, this connection must be disabled again.



In some applications automatic connection between the neutral conductor (N) and earth (PE / GND) is not required or acceptable. Therefore the automatic connection between the neutral conductor (N) and earth (PE / GND) is disabled by default

To enable this automatic connection, see section 6.1.5

5.4 THINGS YOU NEED

Make sure you have all the parts you need to install the Mass Combi:

Quantity needed for parallel operation of two Mass Combi's 

Quantity needed for stand alone operation of one Mass Combi:  

Mass Combi (included)	1	2
Inverter Charger Control (ICC) panel with a grey mounting-case (included)	1	1
Modular communication cable 6 pole (included 6m, maximum length 15m) to connect the inverter charger control panel (ICC panel) to the Mass Combi, see figure 15	1	2
Battery temperature sensor with cable and plug (included).	1	2
DC-cable to connect the positive DC connection (+) of the Mass Combi to the plus pole of the DC-distribution; for specifications see section 9.1, maximum recommended length: 2m / 6ft, colour: preferably red or at least a different colour to make a clear distinction between the positive and negative wire from the battery	1	2
DC-cable to connect the negative DC connection (-) of the Mass Combi to the negative pole of the DC-distribution; for specifications see section 9.1, maximum recommended length: 2m / 6ft, colour: preferably black or at least a different colour to make a clear distinction between the positive and negative wire from the battery.	1	2
DC-fuse holder with a DC-fuse, to be integrated in the positive DC-cable. For specifications see section 5.3.2.	1	2
Screws / bolts (Ø 6mm) (with plugs) to mount the cabinet to a surface. Use mounting materials which are suitable to carry the weight of the Mass Combi	4	8
AC cable* to connect the AC input of Combi A to an external power source (e.g. a shore connection or a generator set);	1	1
AC cable* to connect the external load to the AC "Power" output of Combi A.	1	1
AC cable* to connect the external load to the AC "SHORT BREAK" output of Combi A.	1	1
AC cable* to connect the AC "SHORT BREAK" outputs of both Combi A and B to each other. Maximum length: 15m	-	1
Batteries. Refer to section 9.1 for specifications. See also section 3.8	X	X
Appropriate and reliable cable terminals, cable lugs, battery terminals and cord end terminals	X	X
Modular communication cable 8 pole (maximum length 15m) for communication between the two Mass Combi's. See figure 16.	-	1

* Double insulated three wire cable with wire colours according to the locally applicable regulations. The applicable length and wire diameter depend on the electrical installation (see section 5.3.1).

We recommend as a minimum tool kit:

- Socket wrench 13mm to fix the DC-input (battery) cables
- Flat blade screw driver 1.0 x 4.0 mm to fix the screw terminals
- Tools to fix the screws / bolts (Ø 6mm) with plugs to mount the cabinets to a surface
- Philips screw driver to open the connection area of the Mass Combi

5.5 REMOVAL OF THE FRONT PANEL

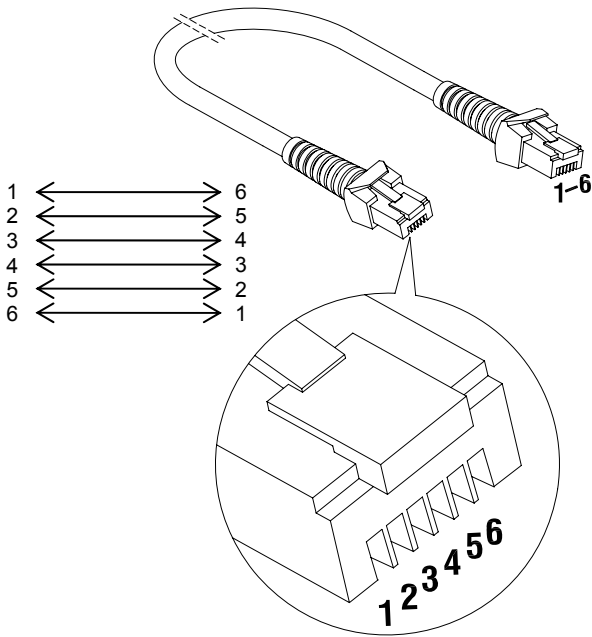

Figure 15: Modular communication cable, 6 pole, cross wired.
For connection of remote control panels

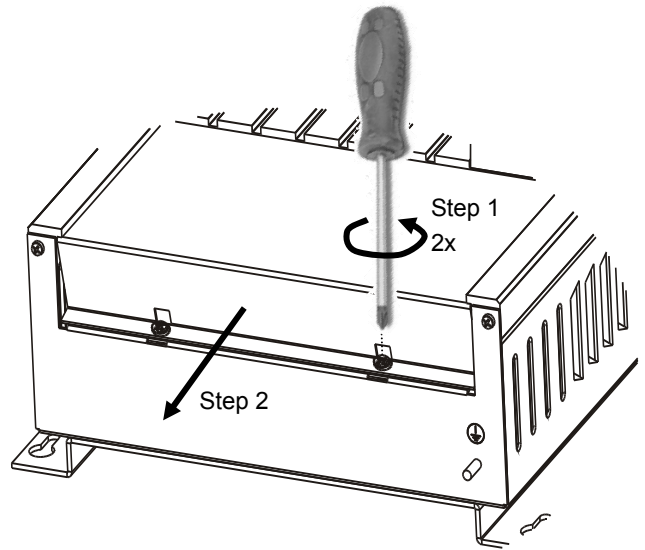

Figure 17

See figure 17. Steps:

- 1 Loosen the two Phillips screws that secure the front cover plate for two turns.
- 2 Slide the front cover plate from the cabinet (downwards).

The connectors for the battery, the AC and the remote panel are now visible. See figures 18 and 19



WARNING

The front panel may never be removed while the Mass Combi is still connected to a power source!

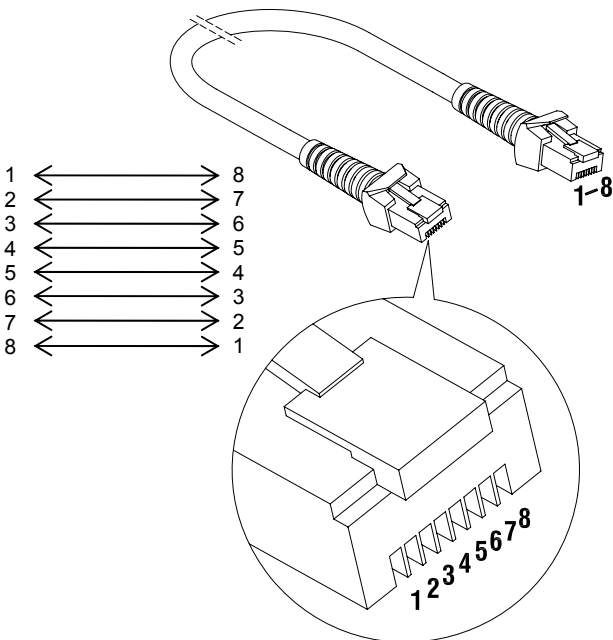

Figure 16: Modular communication cable, 8 pole, cross wired.
For communication between two Mass Combi's (parallel operation)

5.6 OVERVIEW CONNECTION COMPARTMENT

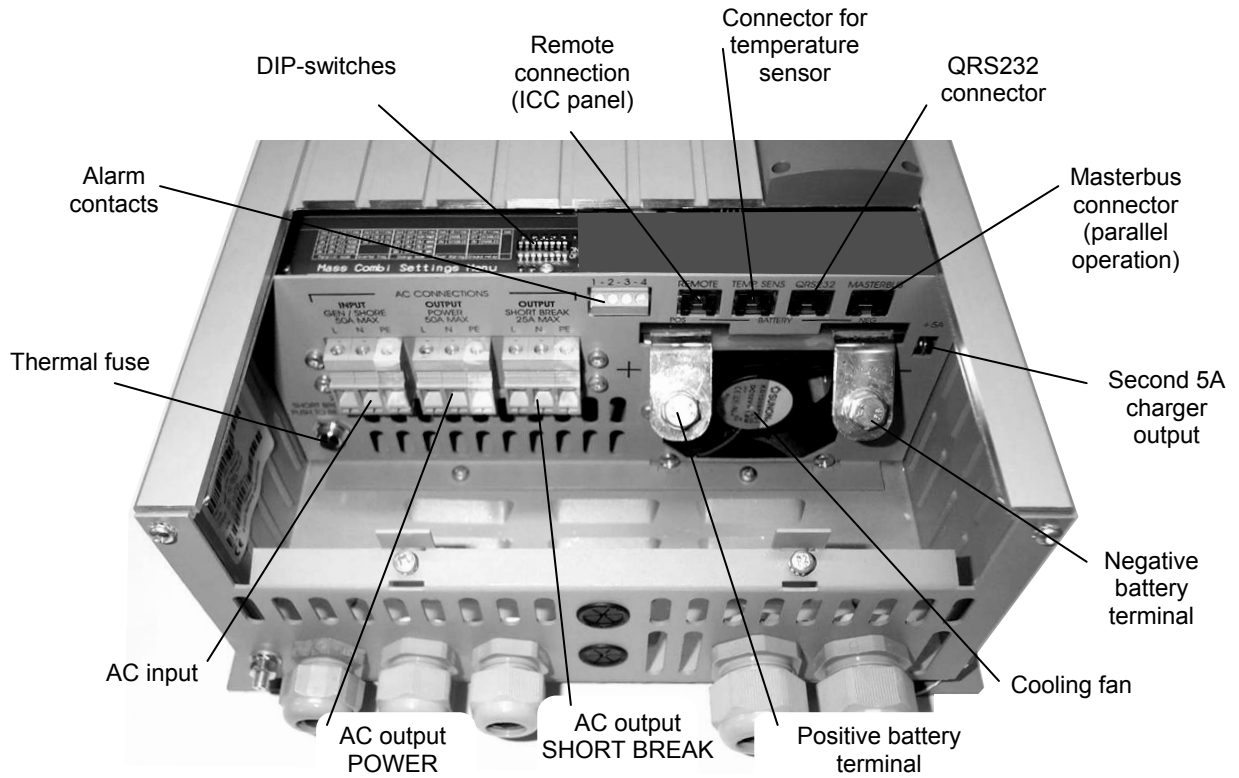

Figure 18: Overview connection compartment Mass Combi 12/2000-100 and 24/2000-60

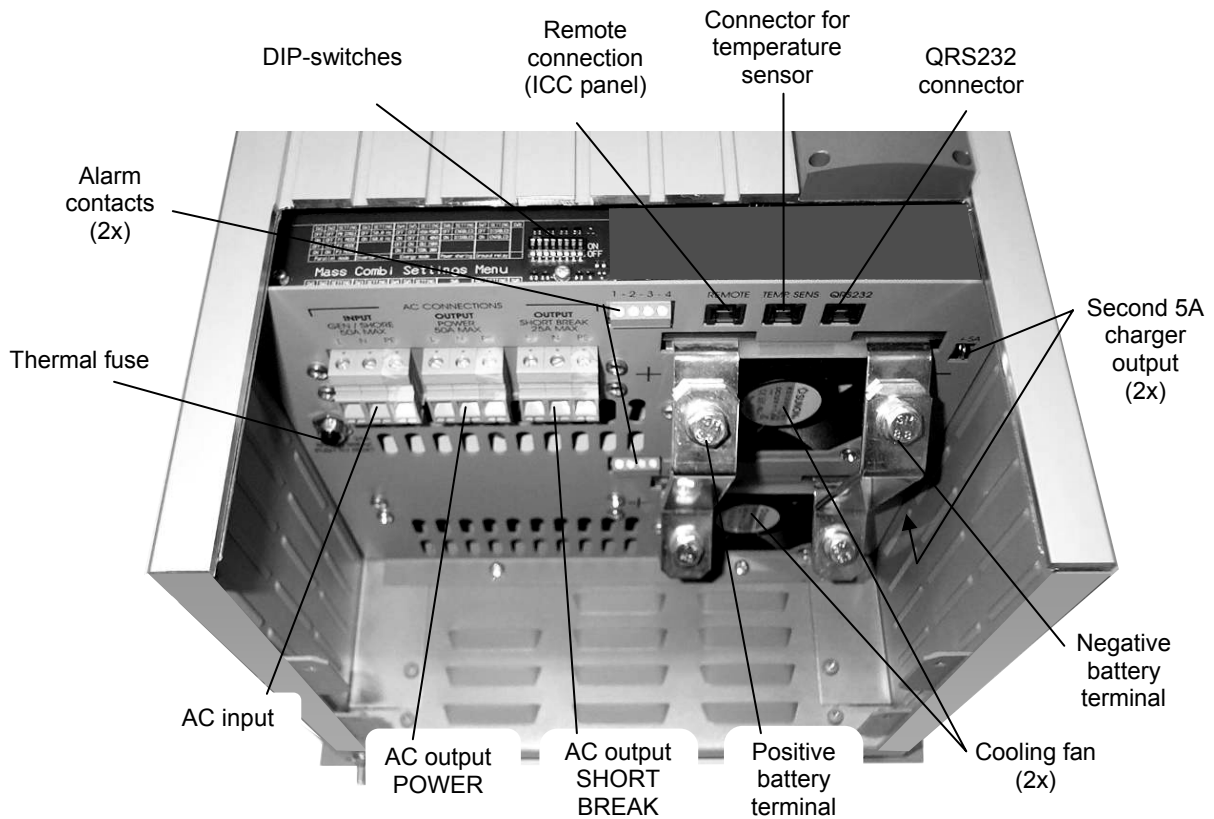

Figure 19: Overview connection compartment Mass Combi 12/4000-200 and 24/4000-120 (Bottom plate removed)

156: Mass Combi 12/2000-100 & 24/2000-60
 279: Mass Combi 12/4000-200 & 12/4000-120

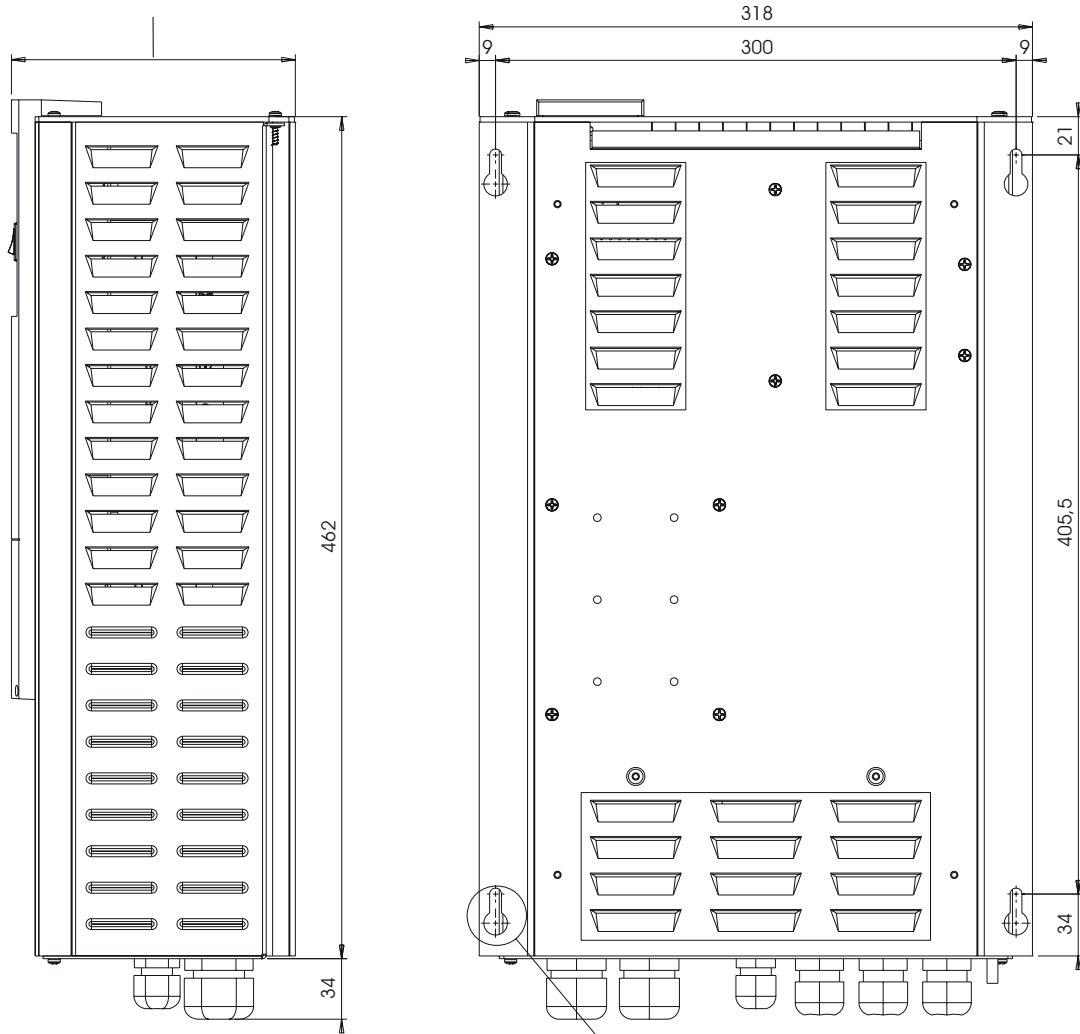

Figure 20:
 Dimensions Mass Combi 12/2000-100, 12/4000-200,
 24/2000-60 and 24/4000-120

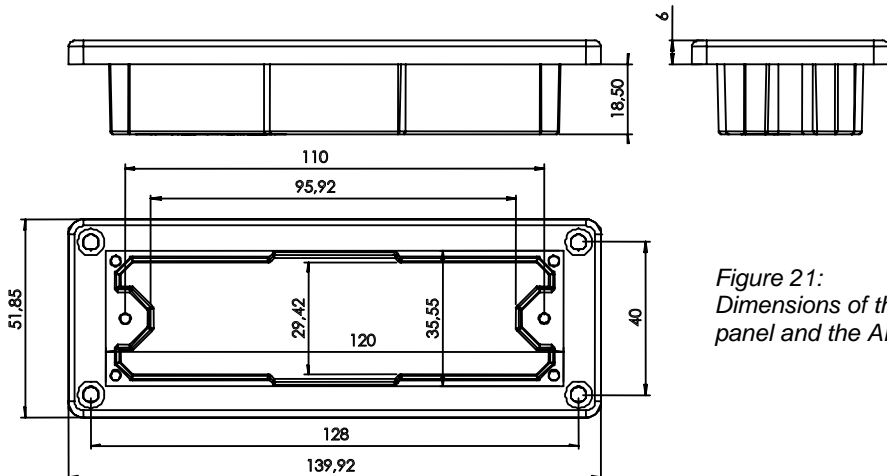

Figure 21:
 Dimensions of the mounting box of the ICC remote
 panel and the APC remote panel

5.7 MOUNTING OF THE CABINET

M6 bolts can be used for the mounting of the cabinet.

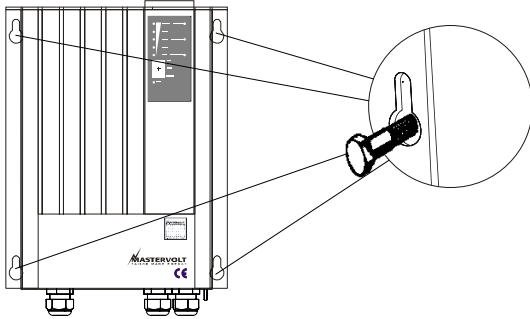

Figure 22: mounting of the cabinet

Take the following steps to mount the cabinet:

- 1 Determine for the four mounting spots on the basis of the outline drawings (figure 20)
- 2 Screw the topmost bolts somewhat into the wall.
- 3 Hang the cabinet with its key holes over the two bolts and screw these bolts finger tight, so that some shifting is still possible.
- 4 Place the two lowermost bolts.
- 5 Fasten all bolts securely.

5.8 WIRING INSTRUCTIONS



WARNING

Let installation work be done by a licensed electrician. Before beginning with the connection of the wiring, make the AC distribution as well as the DC distribution voltage free. Move the main switch (see figure 11) to the "Off"-position.



CAUTION!

Short circuiting or reversing polarity may lead to serious damage to the batteries, the Mass Combi, the cabling and/or the terminal connections. Fuses between the batteries and the Mass Combi can not prevent damage caused by reversed polarity. The damage as a result of reverse polarity is detectable by the service department and is not covered by the warranty.



CAUTION!

Too-thin cables and/or loose connections can cause dangerous overheating of the cables and/or terminals. Therefore tighten all connections well, in order to limit transition resistance as far as possible. Use cables of the correct size



NOTE!

Feed the cables through the cable glands of the cabinet before you fix the cable lugs to the wire ends.

Continue with section 5.8.1 for wiring instructions of one Mass Combi in stand alone operation or section 5.8.2 for wiring instructions of two Mass Combi's in parallel operation.

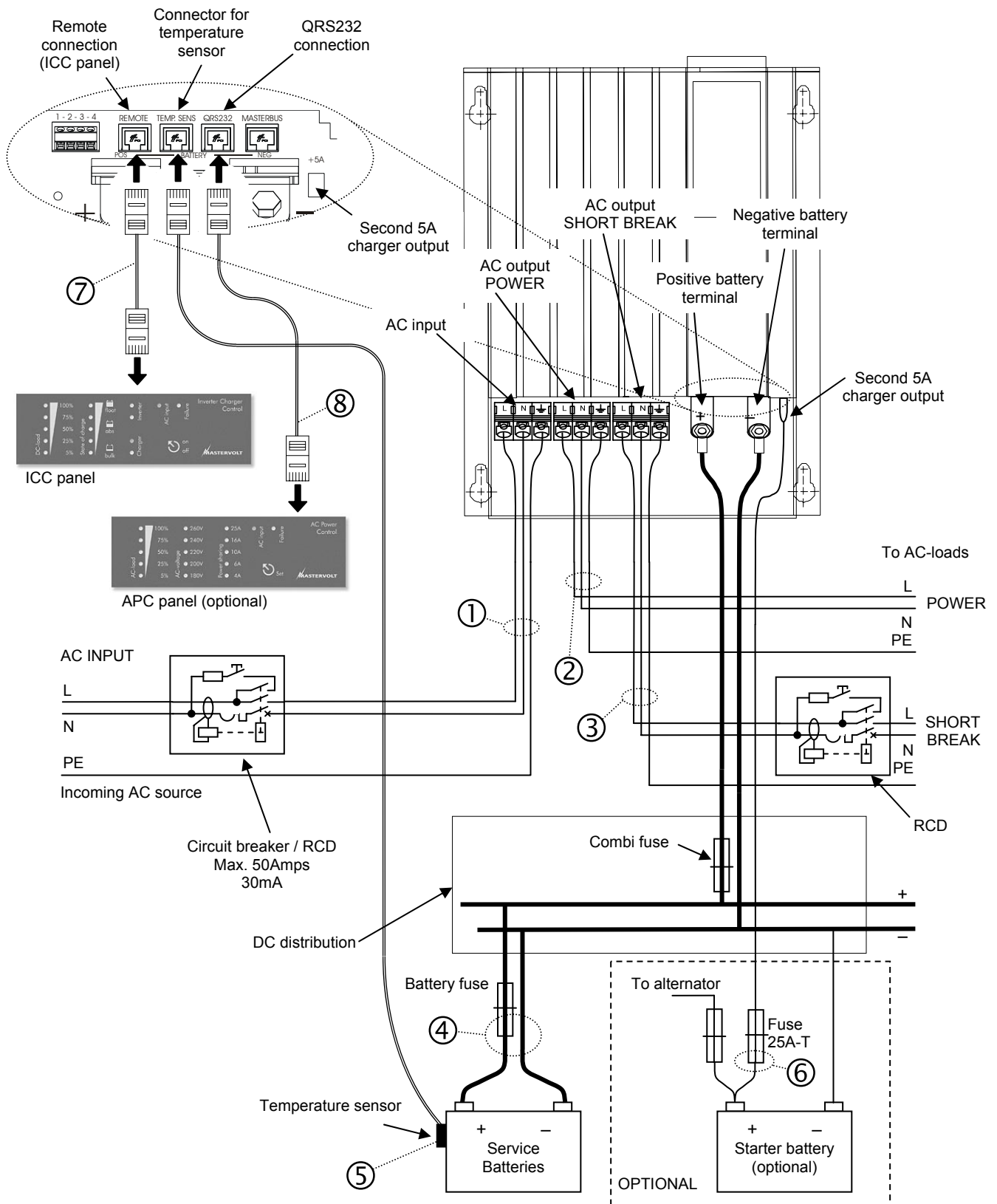

This schematic is to illustrate the general placement of the Mass Combi in a circuit. It is not meant to provide detailed wiring instructions for any particular electrical installation.

Figure 23: installation drawing for one Mass Combi (stand-alone operation)

5.8.1 Wiring instructions for one Mass Combi (stand alone operation)

See figure 23.

- 1 See reference ①. Connect the external AC-source to the AC-input of the Mass Combi. Integrate a fuse (value depending on the used wire diameter with a maximum of 50Amps) and a Residual Current Device (RCD) into this wiring.
- 2 See reference ②. Connect the AC-output POWER of the Mass Combi to the power distribution group.
- 3 See reference ③. Connect the output SHORT BREAK of the Mass Combi to the SHORT BREAK distribution group. Integrate a Residual Current Device (RCD) into this wiring.
- 4 See reference ④. Run the DC-cables between the DC-distribution and the Mass Combi. Connect the red cable to the plus (+) connection, the black cable to the minus (-) connection. Do not install the DC-fuse of the DC-distribution before the entire installation is completed (see chapter 7).
- 5 See reference ⑤. Attach the temperature sensor to the battery and run the cable into the Mass Combi and connect the RJ12 connector to the "TEMP.SENS"-connector (Data Bus Connections)

- 6 Option: if you want to make use of the possibility to give a maintenance charge to a small battery set (like a starter battery), run a 6mm² /AWG10 red cable with a fuse holder between the positive pole of the starter battery and Mass Combi. See figure 23, reference ⑥. Fix the cable with an insulated faston to the "+5A"-connection. Integrate a 25 Amps-T fuse in this wire. The negative pole of this battery must be connected to the negative pole of the service battery.
- 7 See reference ⑦. If you want to install the ICC remote control panel, run the communication cable between the Mass Combi and the panel. Connect the RJ12 connector to the "REMOTE"-input (Data Bus Connections)



NOTE!

The Mass Combi can also be operated without the ICC remote control panel connected.

- 8 Other panels than the ICC remote control panel must be connected to the "QRS232"-connection; reference ⑧. Refer to the applicable installation manual for instructions.

Continue with section 5.8.3

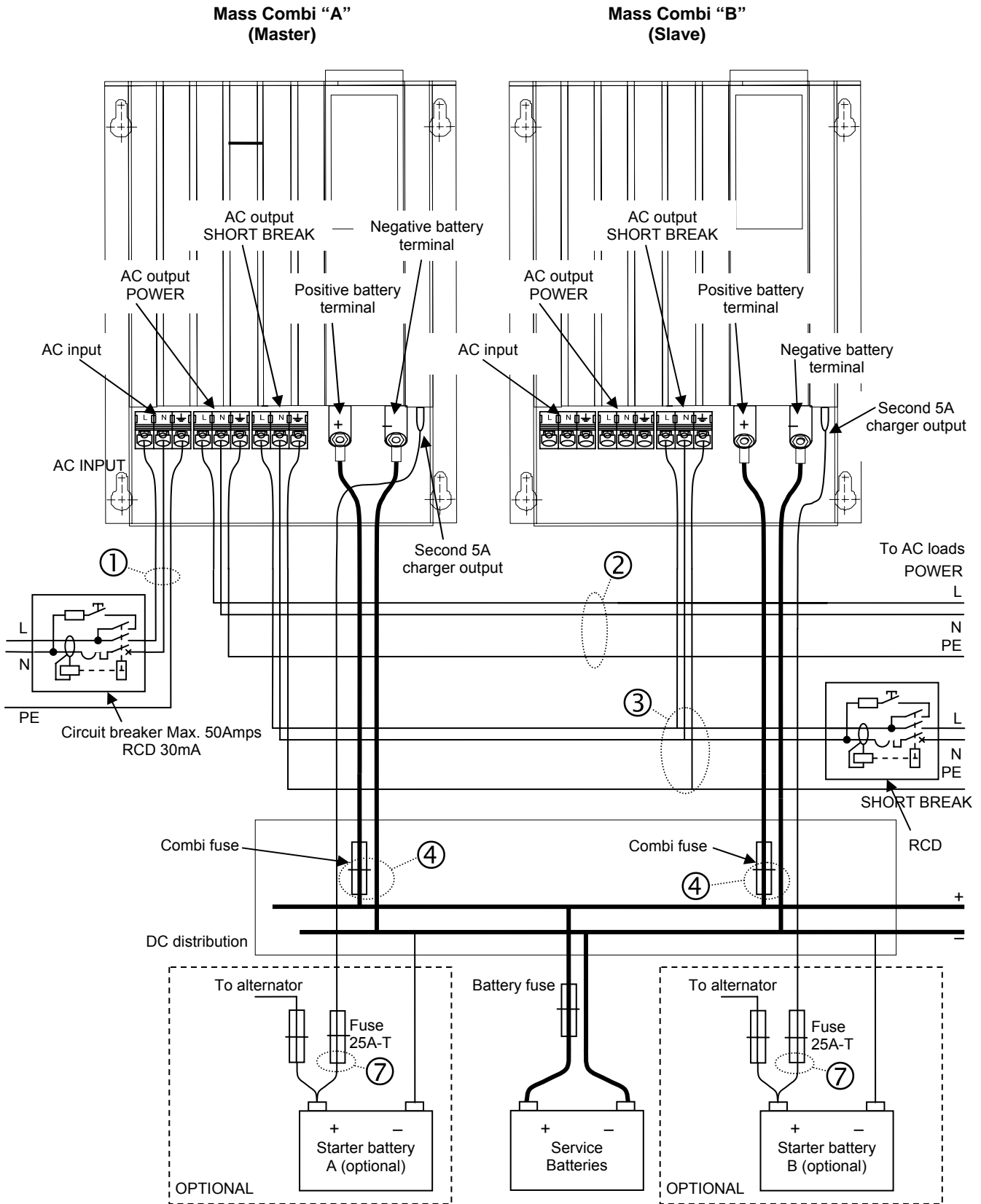

This schematic is to illustrate the general placement of the Mass Combi in a circuit. It is not meant to provide detailed wiring instructions for any particular electrical installation.

Figure 24: installation drawing for two Mass Combi's (parallel operation). See also figure 25

5.8.2 Wiring instructions for two Mass Combi's (parallel operation)



CAUTION!

Only two units of the Mass Combi 12/2000-100 or the Mass Combi 24/2000-60 can be connected in parallel. Parallel operation of two units of the Mass Combi 12/4000-200 or the Mass Combi 24/4000-120 is not possible.

In the text below the Mass Combi that is designated as "A" must be configured as Master, while the Mass Combi that is designated as "B" must be configured as Slave (see section 6.1.1 for adjustment).

Designation:	must be configured as:
Combi A	Master
Combi B	Slave

- 1 See figure 24, reference ①. Connect the external AC-source to the "AC input" terminals of Mass Combi "A". Integrate a fuse (value depending on the used wire diameter with a maximum of 50Amps) and a Residual Current Device (RCD) into this wiring.
- 2 See reference ②. Connect the "AC output POWER" of Combi "A" to the power distribution group.
- 3 See reference ③. Connect the "AC output SHORT BREAK" of both Mass Combi "A" and Mass Combi "B" to the SHORT BREAK distribution. Beware that the L, N and PE / GND wiring may not be exchanged.
- 4 See reference ④. Run the DC-cables between the DC-distribution and each Mass Combi. Connect the red cable to the plus (+) connection, the black cable to the minus (-) connection. Do not install the DC-fuses of the DC-distribution before the entire installation is completed (see chapter 7).
- 5 See figure 25, reference ⑤. Run the modular 8-pole communication cable between Mass Combi "A" and Mass Combi "B". Connect this cable to the MASTERBUS connectors.
- 6 See reference ⑥. Attach the temperature sensor to the battery and run the cable into Mass Combi "A" and connect the RJ12 connector to the "TEMP.SENS"-connector (Data Bus Connections)
- 7 Option: if you want to make use of the possibility to give a maintenance charge to a small battery set (like a starter battery), run a 6mm² /AWG10 red cable with a fuse holder between the positive pole of the starter battery and Mass Combi. See figure 24, reference ⑦. Fix the cable with an insulated faston to the "+5A"-connection. Integrate a 25 Amps-T fuse in this wire. The negative pole of this battery must be connected to the negative pole of the main battery.
- 8 See figure 25, reference ⑧. If you want to install the ICC remote control panel, run the communication cable between Mass Combi A and the panel. Connect the RJ12 connector to the "REMOTE"-input (Data Bus Connections) of Mass Combi A.



NOTES

- The Mass Combi can also be operated without the ICC remote control panel connected.
 - With two Mass Combi's installed in parallel, each Combi can also have its own ICC remote control panel.
- 9 Other panels than the ICC remote control panel must be connected to the "QRS232"-connection; reference ⑨. Refer to the applicable installation manual for detailed instructions.

Continue with section 5.8.3

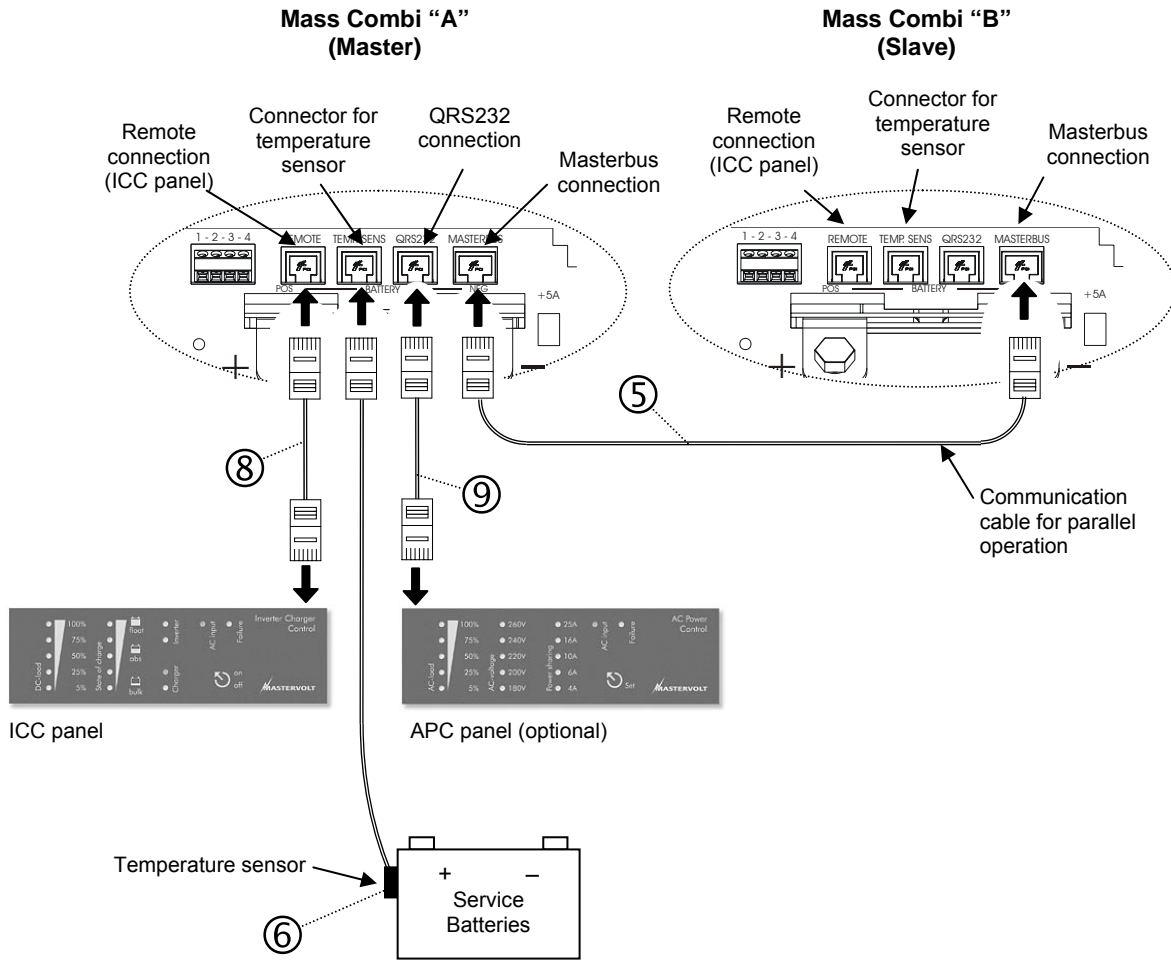

Figure 25: Connection of remote control panels, battery temperature sensors and communication cable for parallel operation

5.8.3 Alarm contacts

Connectors 1 to 4 are internally linked as follows:

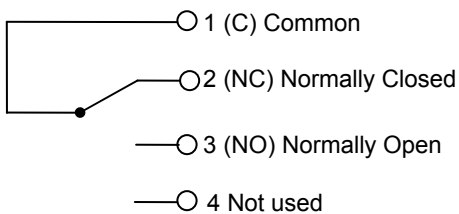
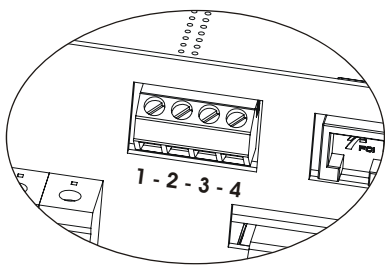

Figure 26: alarm contacts

The alarm contact is switched to “Normally Open” in case of an alarm situation, see section 3.6.

The Mass Combi 12/4000-200 and 24/4000-120 are provided with two sets of alarm contacts. These two sets operate simultaneously

5.9 SETTINGS

The Mass Combi is provided with two groups of DIP-switches to adjust the apparatus according to the specifications of the electrical installation. See chapter 6.



NOTE:
Adjust the DIP-switches prior to commissioning!

6 SETTINGS

The Mass Combi is provided with two groups of DIP-switches to adjust the apparatus according to the specifications of the electrical installation. The DIP-switches are located in the connection compartment. See figure 27.

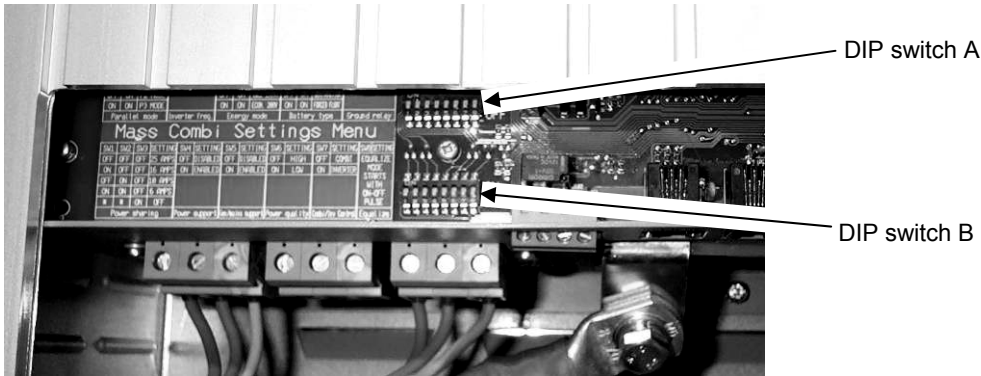

Figure 27: DIP switches

6.1 DIP SWITCH A

SW1	SW2	SETTING	SW3	SETTING	SW4	SW5	SETTING	SW6	SW7	SETTING	SW8	SETTING
OFF	OFF	P0 SINGLE	OFF	50.0 Hz	OFF	OFF	HIGH POWER	OFF	OFF	STANDARD	OFF	DISABLED
ON	OFF	P1 MODE	ON	60.0 Hz	ON	OFF	IDLE 40VA	ON	OFF	GEL - AGM	ON	ENABLED
OFF	ON	P2 MODE			OFF	ON	IDLE 150VA	OFF	ON	SEMITRACTION		
ON	ON	P3 MODE			ON	ON	ECON. 208V	ON	ON	FORCEDFLOAT		
Parallel mode			Inverter freq.		Energy mode			Battery type		Ground relay		

Figure 28:
DIP switch A

6.1.1 Parallel mode

If you want...	Then...	
	SW1	SW2
to configure the Combi as Master (Combi A) then...	OFF	OFF
to configure the Combi as Slave (Combi B) then...	ON	ON
to configure the Combi as Slave (Combi B) having its own charge characteristics then... (only when both Combi A and Combi B have their own battery set)	OFF	ON

NOTES:

- If the Combi is configured as Slave, then the settings of SW3 to SW8 of DIP switch A and SW1 to SW7 of DIP switch B are denied.
- If the charge characteristics of the Combi that is configured as Slave (Combi B) are set to follow the Master (DIP Switch A: SW1= ON) then its settings SW6 to SW7 of DIP switch A are denied.

6.1.2 Output frequency inverter

If you want...	Then...
	SW3
to set the output frequency to 50 Hz	OFF
to set the output frequency to 60Hz	ON

6.1.3 Energy saving mode

See section 3.2.2 for more information.

If you want...	Then...	
	SW4	SW5
High Power (Energy saving disabled).	OFF	OFF
Idle 40VA. When it detects a load that is >40VA, it switches on the output power automatically.	ON	OFF
Idle 150VA. When it detects a load that is >150VA, it switches on the output power automatically	OFF	ON
Economy 208V. The output voltage will drop to 208V as long as the connected load stays below 250VA.	ON	ON

Note: The power saving modes “Idle 40VA” or “Idle 150VA” can only be selected with a Mass Combi 12/2000-100 or a Mass Combi 24/2000-60 operating as stand-alone unit. These modes are not available with a Mass Combi 12/4000-100, Mass Combi 24/4000-120 or two Mass Combi’s in parallel operation.

6.1.4 Battery type

The factory setting for the battery type is optimal for most installations. In some applications however, it is desirable to change this setting. Adjust the Mass Combi to the applied batteries by adjusting DIP switches SW6 and SW7.

Wrong adjustment can cause damage to your batteries which is not covered by the warranty.

The setting for traction battery should never be used with a battery bank that consists of 2V GEL cells!

If you want...	Then...	
	SW6	SW7
Standard battery (factory setting)	OFF	OFF
Gel / AGM / spiral battery. During the float stage of the charging cycle the output voltage will be higher (+ 0.55V @ 12V / + 1.1V @ 24V)	ON	OFF
Traction battery. Charging voltage will be increased during the bulk stage (+ 0.7V) and the absorption stage (+ 0.4V)	OFF	ON
Forced float. When activated, the three stage charging program is changed to a single stage program.	ON	ON
Fixed output voltage: 13.8V (@12V) or 27.6V (@24V)		

6.1.5 Ground relay

The ground relay function allows you to connect the Neutral conductor (N) of the inverter output circuit to the Safety Ground (PE / GND) automatically when the Mass Combi is working as an inverter. Refer to local regulations on this issue.

If you want...	Then...
	SW8
no internal connection between the Neutral (N) and the Safety Ground (PE / GND) when the Mass Combi is working as an inverter	OFF
the Neutral wire (N) of the inverter output circuit connected to the Safety Ground (PE / GND) when the Mass Combi is working as an inverter and disconnected when incoming AC-power is applied (charger / transfer mode).	ON

6.2 DIP SWITCH B

SW1	SW2	SW3	SETTING	SW4	SETTING	SW5	SETTING	SW6	SETTING	SW7	SETTING	SW8	SETTING
OFF	OFF	OFF	25 AMPS	OFF	DISABLED	OFF	DISABLED	OFF	DISABLED	OFF	DISABLED	EQUALIZE MODE STARTS WITH ON-OFF PULSE	
ON	OFF	OFF	16 AMPS	ON	ENABLED	ON	ENABLED	ON	ENABLED	ON	ENABLED		
OFF	ON	OFF	10 AMPS										
ON	ON	OFF	6 AMPS										
*	*	ON	OFF										
Power sharing				Power support		Gen/mains support		Power quality		Combi/inv control		Equalize	

Figure 29:
DIP switch B

6.2.1 Power sharing function

See section 3.3.3 for more information.

If you want...	Then...		
	SW1	SW2	SW3
To limit the AC-input current to 25 Amps.	OFF	OFF	OFF
To limit the AC-input current to 16 Amps.	ON	OFF	OFF
To limit the AC-input current to 10 Amps.	OFF	ON	OFF
To limit the AC-input current to 6 Amps.	ON	ON	OFF
To disable the Power sharing function.	---	---	ON

6.2.2 Power Support Function

See section 3.3.5 for more information.

If you want...	Then...
	SW4
To disable the Power support function	OFF
To enable the Power support function	ON

6.2.3 Generator / mains support function

See section 3.3.4 for more information.

If you want...	Then...
	SW5
To disable the Generator / mains support function	OFF
To enable the Generator / mains support function	ON

6.2.4 Setting for Power Quality at incoming AC

If you want...	Then...
	SW6
To set the frequency window for the incoming AC power at $45\text{Hz} < f < 65\text{Hz}$	OFF
To set the frequency window for the incoming AC power at $35\text{Hz} < f < 65\text{Hz}$	ON



CAUTION!

Adjustment of the frequency window at a too low level may cause damage to the connected AC-load. Refer to the AC-input specifications of the connected loads.

6.2.5 Combi/inverter control

The ON/OFF switch at the Inverter Charger Control (ICC) panel has different functions depending on the setting of DIP-switch number 7.

When the Mass Combi is switched off by means of the main switch at the front then it is completely off (see 4.2). However, in this off state it is not possible to start the Mass Combi remotely via the ICC remote panel. This is independent from the setting of DIP-switch number 7.

When you want to charge your batteries only and you do not want to start the inverter function when incoming AC fails then set the main switch in the Ch. (Charger only see 4.2.3). In this state it is not possible to switch the Mass Combi remotely on or off. This is independent from the setting of DIP-switch number 7.

If you want...	Then... SW7
To switch the Mass Combi (inverter and charger function) remotely on or off. The main switch at the front of the Mass Combi has to be set to the ON position	OFF
To switch the inverter function of the Mass Combi remotely on or off when AC-in fails. With this setting the charger is always active when the AC-in is available. The main switch at the front of the Mass Combi has to be set to the ON position.	ON



NOTE:

The Mass Combi is not entirely off when the Mass Combi is switched off via the ICC remote panel. The no load drain is less than 5mA and is used to keep the data buses connected to the remote panels active

6.2.6 Equalize mode



WARNING

Incorrect use of the equalize mode may lead to hazardous situations



WARNING

Equalization is ONLY applicable for wet type batteries and will damage gel and AGM type batteries..



WARNING

Do not smoke; use any naked flame or other sources of ignition due to risk of explosion. Always ventilate the room where the batteries are located and equalized to clear the air..

The equalizing mode can only be started when the Mass Combi is in operation. This means that the connection compartment of the Mass Combi must be opened while connected to the mains and the batteries. Take adequate measures for protection against short circuits and electrical shocks.

During equalizing the batteries are brought into the gas state and it is possible that the permitted load voltages are exceeded. Therefore appropriate measures must be taken, e.g. disconnect all loads from the battery and ventilate the room. For these reasons use of the equalizing mode should only be executed by trained technical engineers.

An equalizing charge can be necessary after very deep discharges and/or inadequate charges. This has to be carried out according to the specifications of the manufacturer of the batteries.

If you want...	Then... SW8
To start the equalize mode	Off-On-Off pulse

7 START-UP AFTER INSTALLATION

7.1 COMMISSIONING

**CAUTION!**

Check the polarity of all wiring before commissioning: plus connected to plus (red cables), minus connected to minus (black cables)

**NOTE:**

The DIP-switches must be adjusted prior to commissioning; see chapter 6

Follow the steps described below to switch on the Mass Combi.

- 1 Tighten all cable glands to ensure the pull relief
- 2 Check all wiring and connections
- 3 Close the front cover plate of the connection compartment of the Mass Combi. Beware that the cabling does not obstruct the cooling fans and air flow.
- 4 Place the DC-fuse(s) of the DC-distribution to connect the batteries to the Mass Combi.

**WARNING**

When placing this fuse, a spark can occur, caused by the capacitors used in the Mass Combi. This is particularly dangerous in places with insufficient ventilation, due to the gassing of the batteries an explosion can occur and avoid having flammable materials close by.

Now the Mass Combi is ready for operation.

7.2 DECOMMISSIONING

If it is necessary to put the Mass Combi out of operation, follow the instructions in order of succession as described below:

- 1 Move the Main-switch of the Mass Combi to the "Off"-position (see figure 11).
- 2 Remove the DC-fuse(s) of the DC-distribution and/or disconnect the batteries.
- 3 Remove the AC-fuse(s) of the AC-input and/or disconnect the AC-mains.
- 4 Open the connection compartment of the Mass Combi (see section 5.5)
- 5 Check with a suitable voltage meter whether the inputs and the outputs of the Mass Combi are voltage free.
- 6 Disconnect all the wiring

Now the Mass Combi can be demounted in a safe way.

8 TROUBLE SHOOTING

8.1 FAULT INDICATORS

If a failure occurs, the origin of the failure is displayed by means of the LEDs at the front of the Mass Combi.

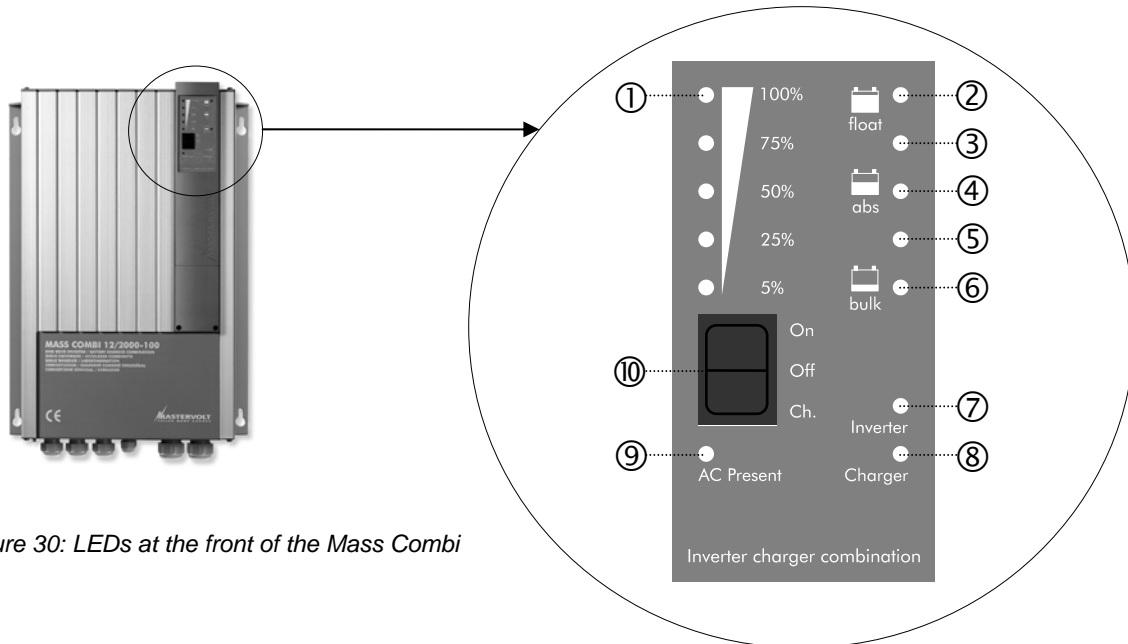

Figure 30: LEDs at the front of the Mass Combi

Mode	Illuminating LEDs	Explanation / Possible cause	What to do
--	None	The Mass Combi is switched off manually.	Switch on the Mass Combi by means of the On/Off/Ch. –switch. Also check the on/off switch of the ICC remote panel
		DC-fuse is blown	Investigate the cause of the failure and replace the fuse.
	7 is lit, 8 and 9 are flashing fast	Thermal fuse is blown.	Reset the thermal fuse. See 4.3.1.
	7 is lit 9 is flashing fast	Insufficient quality of AC-in (Shore or Generator)	Check the generator if you use one and wiring (To thin and/or long cables)
	7 is lit red and 9 is lit green	AC-in from Shore or Generator connected to the Short Break output.	Disconnect the AC-in cable from the Short break output.
Charger	2 and 8	Temperature Compensation (TC) error. The temperature sensor on the battery gives an incorrect value.	Disconnect the sensor and if the LED's go off then replace the battery temperature sensor.
	3 and 8	DC voltage error. The battery voltage is too high or too low.	Check the batteries.
	4 and 8	Short circuit error. The battery voltage is far too low. The charger reduces the output current till 25% of the maximum output current.	Check the batteries and the wiring.
	5 and 8	Overheating error. The charger current is reduced to zero in case of extreme overheating until the Mass Combi is cooled down.	Check whether the air flow of the Mass combi is blocked or whether the ambient temperature is too high.

Mode	Illuminating LEDs	Explanation / Possible cause	What to do
Inverter	1 and 7 are lit red	Overload error. The inverter is loaded with more than 2 kW / 4kW.	Reduce the connected load by switching off some equipment.
	3 is lit and 7 is flashing red	DC voltage error. The battery voltage is too high or too low.	Check the batteries and the wiring.
	4 is lit and 7 is flashing red	The inverter output voltage is lower than 180V AC.	Reduce the connected load.
	5 and 7	Overheating error. The inverter is off because of high temperature.	Reduce the connected load and let the Mass Combi cool down.
	1 is lit red and 7 is flashing red	The inverter is permanently off until a manual reset by means of the main switch.	Disconnect all loads and restart the Mass Combi by switching the unit manually off and on with the main switch.

Table 5 : Failure codes of the Mass Combi.

If you cannot solve a problem with the aid of this table, contact your local Mastervolt Service Centre. See www.mastervolt.com. Make sure you have the following information present if you have to contact your local Mastervolt Service Center to solve a problem:

Article and serial number (See section 1.6)

Software version (See section 8.2)

8.2 SOFTWARE VERSION

The version of the installed software can be derived from the illuminating LED's on the front panel during start-up.

Proceed as follows:

- Set the power switch (10) of the Mass Combi to the "On"-position.
- All indicators are illuminated for a second.
- Then the LED's (3) and (4), which are representing the digits upfront the dot, and LED's (5) and (6) which are representing the digit after the dot, are showing the version number of the software by flashing. See the table below, the software version in this example is 1.32:

LED number	(3)	(4)	(5)	(6)
Software version	--	1	3	2
Number of times illuminated	0	1	3	2

Table 6 Software version

- After showing the installed software version the Mass Combi will switch on.

9 TECHNICAL DATA

9.1 SPECIFICATIONS INVERTER

Model Mass Combi 230VAC	12/2000-100	12/4000-200	24/2000-60	24/4000-120
Partnumber 230VAC	36012005	36014005	36022005	36024005
Model Mass Combi 120VAC	12/2000-100	12/4000-200	24/2000-60	24/4000-100
Partnumber 120VAC	37012005	37014005	37022005	37024005

DC input

Nominal battery voltage	12V	12V	24V	24V
Operating input voltage range	10.0 – 15.0V	10.0 – 15.0V	19.0 – 31.0V	19.0 – 31.0V
Absolute maximum voltage range (No defects)	0.0 – 16.0V	0.0 – 16.0V	0.0 – 32.0 V	0.0 – 32.0 V
Low battery switch off* (1-30 sec delay)	10.0V ±5%	10.0V ±5%	19.0V ±5%	19.0V ±5%
Low battery switch on*	11.0V ±5%	11.0V ±5%	22.0V ±5%	22.0V ±5%
High battery switch off* (No delay)	15.0V ±5%	15.0V ±5%	31.0V ±5%	31.0V ±5%
High battery switch on*	14.5V ±5%	14.5V ±5%	29.5V ±5%	29.5V ±5%
Max. ripple allowed on DC (No defects)	5 % RMS	5 % RMS	5 % RMS	5 % RMS
Nominal current at full load	200A	400A	100A	200A
Maximum peak current	400A	800A	200A	400A
Recommended Fuse	250A	500A	125A	250A
Wire size	2x 70mm ² / AWG2/0	4x 70mm ² / AWG2/0	2x 50mm ² / AWG0	2x 70mm ² / AWG0
Recommended batteries	200~600Ah	400~1200Ah	100~300Ah	200~600Ah

DC No load power consumption

Off mode	0mA	0mA	0mA	0mA
High power mode 230V / 0A (120V / 0A)** out	< 9W	< 18W	< 9W	< 18W
Economic mode, 208V/0A (104V/0A)** out	< 8W	< 16W	< 8W	< 16W
Idle mode, 5 pulses per 2½ sec	< 0,5W	< 1W	< 0,5W	< 1W

AC output

Nominal voltage (±5%)	230VAC (190– 240VAC)* (120VAC (90– 135VAC)*)**			
Wave form	True sine wave, max 5% distortion, 2½% typical			
Frequency	50Hz (60Hz)** +/- 0.05% (adjustable by DIP switch)			
Maximum continuous output power (AC-out: 230V, resistive load)				
At 25°C / 77°F ambient temperature	2000VA (DC-in ≥11.0V)	3750VA (DC-in ≥11.0V)	2000VA (DC-in ≥22.0V)	3750VA (DC-in ≥22.0V)
At 40°C / 104°F ambient temperature	1800VA (DC-in ≥11.0V)	3600VA (DC-in ≥11.0V)	1800VA (DC-in ≥22.0V)	3600VA (DC-in ≥22.0V)
Output power vs. ambient temperature	>25°C / 77°F derating –0.65% per °C / –1.15% per °F, Shutdown at 80°C / 176°F internal temperature.			
Surge capability (5 sec, resistive load)	4000W	7500W	4000W	7500W
Efficiency (100VA up to 2000VA)	≥90%			
Load power factor range	All power factor allowed			
Protections	Over temperature, overload, short circuit, AC on output, high battery, low battery.			

* adjustable by means of MasterAdjust software

** 120V models

9.2 SPECIFICATIONS CHARGER

Model Mass Combi 230V	12/2000-100	12/4000-200	24/2000-60	24/4000-120
AC input				
Nominal voltage / frequency	230V 50/60Hz			
Input voltage, 100 % output	207 ... 265VAC			
Input voltage, reduced output power	180 ... 207VAC			
Absolute maximum voltage range	0 ... 265VAC			
Input frequency range	45 ... 65Hz			
Absolute maximum frequency range	0 ... 70Hz			
Nominal input current (@230V)	7.2 A	14.4 A	8.5 A	17 A
Input phase	Single phase, 3 wire system			
Insulation class	Class I			
Power factor	> 0,98			
Harmonic distortion THD	3%			
Efficiency at full output	> 85%			
No-load power consumption	< 15W	< 30W	< 15W	< 30W
Model Mass Combi 120V				
AC input				
Nominal voltage / frequency	120V 60/50Hz			
Input voltage, 100 % output	105 ... 135VAC			
Input voltage, reduced output power	90 ... 105VAC			
Absolute maximum voltage range	0 ... 135VAC			
Input frequency range	45 ... 65Hz			
Absolute maximum frequency range	0 ... 70Hz			
Nominal input current (@120V)	14.5 A	29 A	17 A	29 A
Input phase	Single phase, 3 wire system			
Insulation class	Class I			
Power factor	> 0,98			
Harmonic distortion THD	3%			
Efficiency at full output	> 85%			
No-load power consumption	< 15W	< 30W	< 15W	< 30W
Model Mass Combi 230VAC				
	12/2000-100	12/4000-200	24/2000-60	24/4000-120
Model Mass Combi 120VAC				
	12/2000-100	12/4000-200	24/2000-60	24/4000-100
DC output				
Nominal output voltage	12VDC (0...15.5VDC)*	12VDC (0...15.5VDC)*	24VDC (0...31.0VDC)*	24VDC (0...31.0VDC)*
Max. output current	100A @ U ≤ 14,25VDC	200A @ U ≤ 14,25VDC	60A @ U ≤ 28,5VDC	120A @ U ≤ 28,5VDC
Max. output current equalize mode	6A @ U > 15,5VDC	12A @ U > 15,5VDC	3.6A @ U > 31.0VDC	7.2A @ U > 15,5VDC
Second charge output:	5A	2x5A	5A	2x5A
Charge characteristic	Three stage, fully automatic, IUoUo, Equalize			

Model Mass Combi 230VAC	12/2000-100	12/4000-200	24/2000-60	24/4000-120
Model Mass Combi 120VAC	12/2000-100	12/4000-200	24/2000-60	24/4000-100
Factory settings				
Return Amps*	6% of maximum output current			
Max bulk, abs timer*	6 hours			
Return amps timer*	15 minutes			
Return to bulk voltage*	12.80V	12.80V	25,60V	25,60V
Return to bulk delay time*	30 seconds			
Battery temperature compensation	-30mV per °C / -17mV per °F		-60mV per °C / -33mV per °F	
Battery voltage sense	automatic voltage compensation			
Protections	Short circuit (current is reduced to 25% of I-max)			

Battery types	Acid	Gel AGM/ Spiral	Traction **
Bulk	14.40V / 28.80V	14.40V / 28.8V	14.60V / 29.20V
Charge voltage Absorption*	14.25V / 28,50V	14.25V / 28.50V	14.45V / 28.90V
Charge voltage Float*	13.25V / 26.50V	13.80V / 27.20V	13.25V / 26.50V
Forced to Float	13.25V / 26.50V	13.80V / 27.20V	13.25V / 26.50V

* adjustable by means of MasterAdjust software.

** traction max ABS/BULK time + 120min.

9.3 MISCELLANEOUS

Switch over system

AC transfer fuse	Yes, by means of resetable fuse
Reverse polarity protection	None.
Overheat protection	Yes, derating above 80°C / 176°F on Power Heat sink
Type of Transfer	Automatic
Type of Switch	2 pole relay
Continuous rating	25A @ 230V, 35A @ 120V
Transfer speed	25ms max, 10ms typical
Inverter synchronized to line before transfer	Yes.
Transfer (interruptible free)	Half seamless.
Power sharing mode	Yes, adjustable via DIP-switches, see 6.2, or via the remote APC see 4.5.
Ground relay	Standard ground relay for connection of neutral of inverter to ground only at inverter mode. (Export models). Can be enabled by installer.
AC cable size IN & OUTPUT	2,5mm ² – 6 mm ² (Depending on your electrical installation)
Battery connections	Bolt M8.
Slave charger output 5 amps	Faston, is switched off in inverter mode

Environmental Specifications

Max dimensions (HxWxD)	496 x 318 x 156 mm	496 x 318 x 279 mm	496 x 318 x 156 mm	496 x 318 x 279 mm
Weight	11kg / 24lbs	21kg / 46lbs	11kg / 24lbs	21kg / 46lbs
Operating temperature range	SPECIFIED, will meet specified tolerances. 0°C to 25 °C / 32 to 77°F			
ALLOWED, may not meet specified tolerances.	-25°C to 60°C / -13 to 140°F			
NON-OPERATING, storage.	-25°C to 85°C / -13 to 185°F			
Humidity	Max 95% relative humidity, not condensing.			
Environment class	IP 23			
Cooling	Mix of conventional and forced air cooling, by DC fans with variable speed.			
Fan operation	The fan does operate on a temperature current control related PWM variable speed control. DC maintenance free fan.			

9.4 CHARACTERISTICS

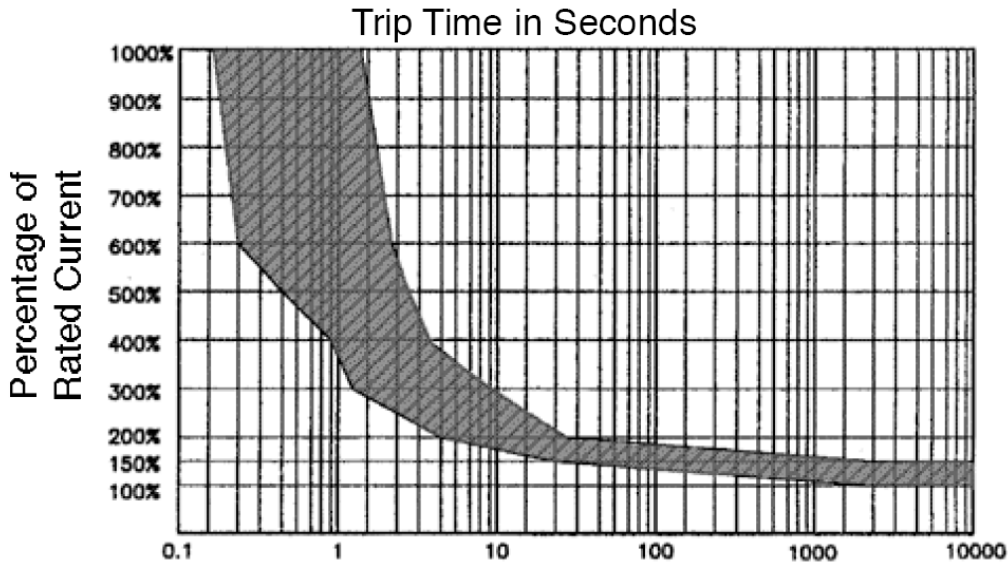

Figure 31: Switch off characteristic of the thermal fuse (@ 25°C / 77°F)

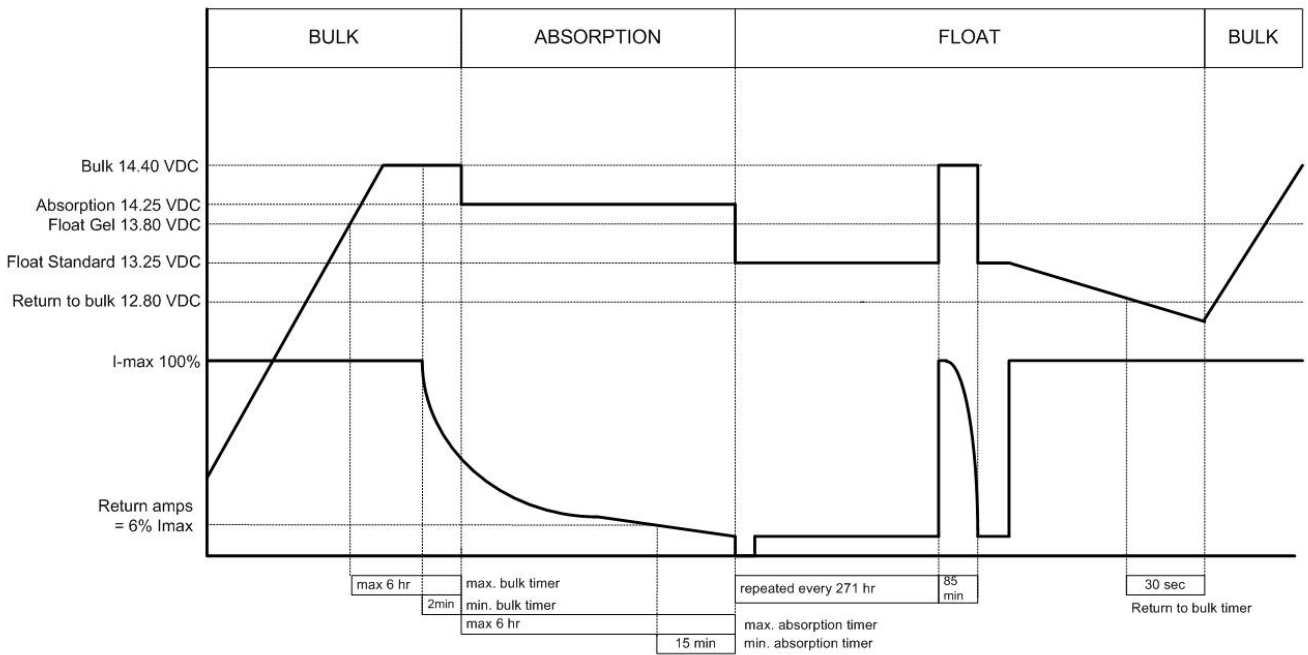

Figure 32: Charge characteristic of the three-step Plus charging method (@ 25°C / 77°F)

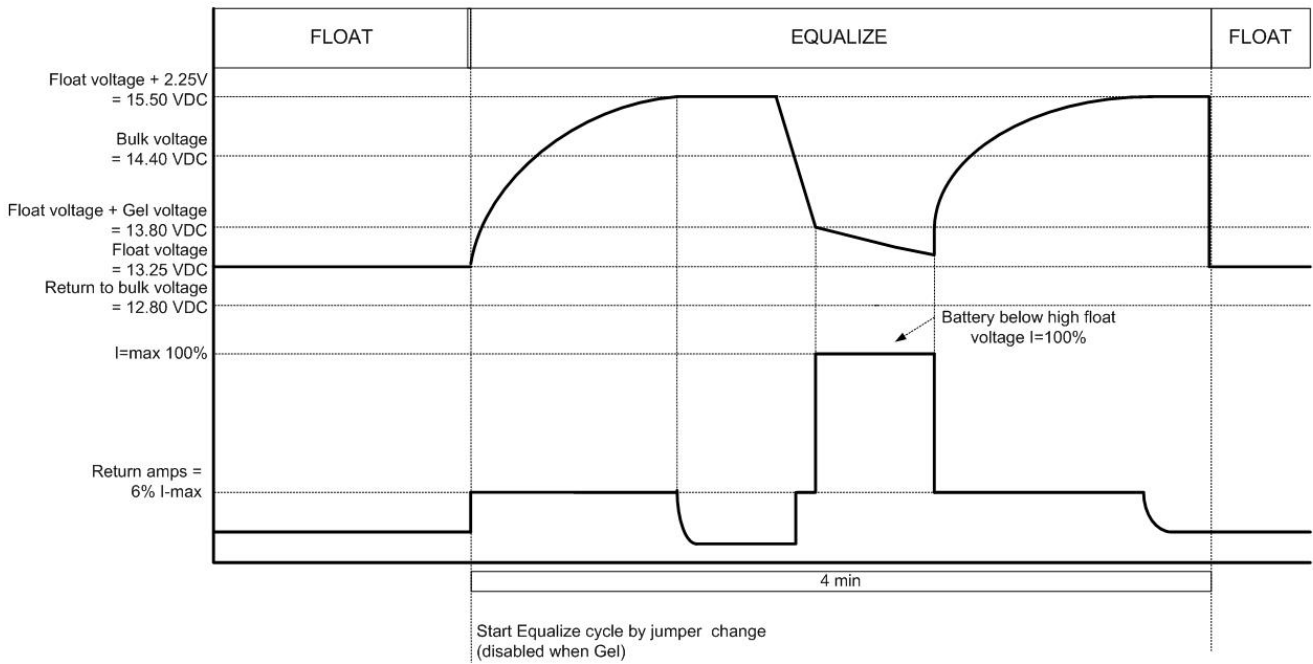

Figure 33: Charge characteristic of the equalize charge cycle (see section 6.2.6) (@ 25°C / 77°F)

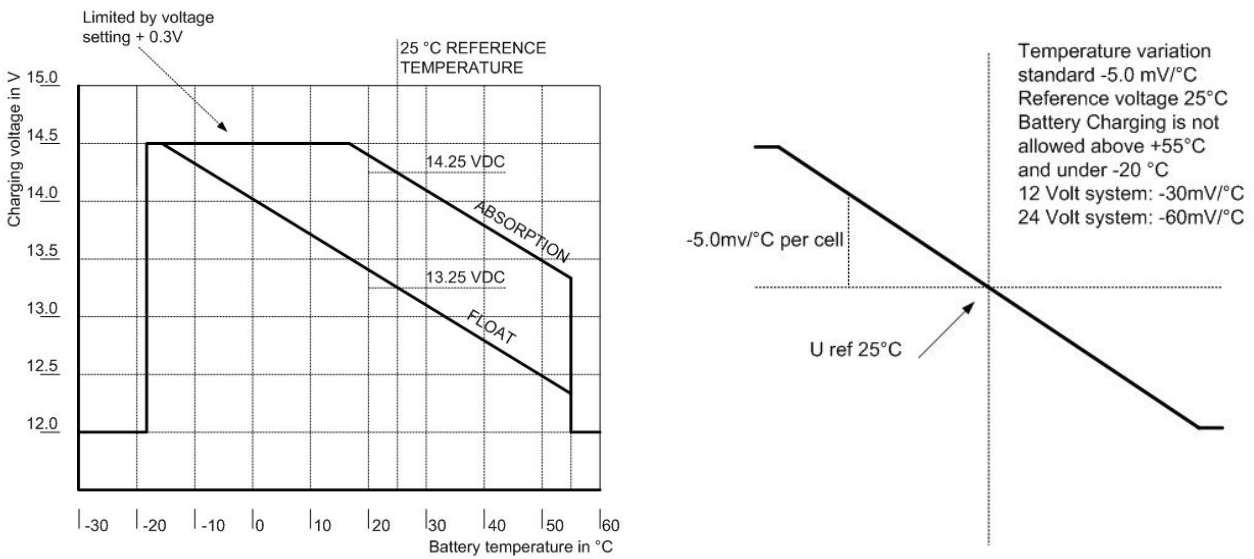

Figure 34: Temperature compensation characteristic (charge voltage versus temperature)

10 ORDERING INFORMATION

Part number	Description
6384012500	Industrial DC fuse 125A DIN 00
6384512500	Industrial DC fuse 125A DIN 1
6384525000	Industrial DC fuse 250A DIN 1
6384640000	Industrial DC fuse 400A DIN 2
6381001000	Fuse base DIN 00 (max. 160A)
6381002000	Fuse base DIN 1 (max. 250A)
6381003000	Fuse base DIN 2 (max. 400A)
79009006	Battery switch 250A with knob
79009005	Battery switch 250A with key
6502001030*	Modular communication cable, cross wired, 6 pole, 6 meter / 19 ft
6502100100	Modular communication cable, cross wired, 6 pole, 10 meter / 33 ft
6502100150	Modular communication cable, cross wired, 6 pole, 15 meter / 49 ft
130010905	Modular communication cable, cross wired, 8 pole, 1 meter / 3 ft
130010906	Modular communication cable, cross wired, 8 pole, 5 meter / 16 ft
130010910	Modular communication cable, cross wired, 8 pole, 10 meter / 33 ft
130010915	Modular communication cable, cross wired, 8 pole, 15 meter / 49 ft
41500500*	Battery temperature sensor, incl. 6 meter / 19 ft cable
70405000*	Inverter Charger Control (Remote ICC), See section 3.5.1
70405010	AC Power Control Panel (Remote APC), See section 3.5.2
70603250	M-3-R1 Adapter for the mounting of a Remote ICC or APC in a Mastervision panel
70403080	Masterlink MICC, remote control panel for Mass Combi. Features: On/Off, status read out, Power Support, extended battery monitoring functions See section 3.5.3
21730100	PC link RS232-QRS232 (without galvanic isolation) required to use with MasterAdjust software
21730300	PC link RS232-QRS232 ISOLATED (with galvanic isolation) required to use with MasterAdjust software

* These parts are standard included with the delivery of the Mass Combi

Mastervolt can offer a wide range of products for your electrical installation, including automatic AC transfer switches, remote control panels and DC distribution kits

See our website www.mastervolt.com for an extensive overview of all our products

11 EC DECLARATION OF CONFIRMITY

Manufacturer Mastervolt
Address Snijdersbergweg 93
1105 AN Amsterdam
The Netherlands



Herewith declares that:

Product:

36012005	Mass Combi 12/2000-100 / 230V
36014005	Mass Combi 12/4000-200 / 230V
36022005	Mass Combi 24/2000-60 / 230V
36024005	Mass Combi 24/4000-120 / 230V
37012005	Mass Combi 12/2000-100 / 120V
37014005	Mass Combi 12/4000-200 / 120V
37022005	Mass Combi 24/2000-60 / 120V
37024005	Mass Combi 24/4000-100 / 120V

Is in conformity with the provision of the EC, EMC directive 89/336/EEC and amendments 92/31/EEC, 93/68/EEC

The following harmonized standards have been applied:

Generic emission standard EN 50081-1:1992,
Generic immunity standard EN 50082-1:1997,

And the safety directive 73/23/EEC and amendment 93/68/EEC, with the following standard:

Low voltage standard EN 60950:2000,

Amsterdam,



R.J. ter Heide,
General Manager MASTERVOLT